

Assembly and Operating manual

GEDA[®] **MULTILIFT P6** **STANDARD / COMFORT**

Construction hoist
For personnel and loads



Mertinger Straße 60 • D-86663 Asbach-Bäumenheim

Phone + 49 (0) 9 06 / 98 09- 0

Fax + 49 (0) 9 06 / 98 09-50

Email: info@geda.de

WWW: <http://www.geda.de>

Copy of the EC Conformity Declaration

EC Declaration of Conformity



The manufacturer

GEDA-Dechentreiter GmbH & Co. KG
Mertinger Str. 60
DE-86663 Asbach-Bäumenheim

hereby declares that the machine

Designation: **Construction hoist for personnel and loads**
(for temporary, non-public use by authorised persons)

Type: **GEDA® MULTILIFT P6**

Year of manufacture: see type plate of the machine

Serial No.: 11M / 12M

is in compliance with all pertinent provisions of the following directives at the time of being put on the market.

<u>Directives:</u>		<u>Applied conformity evaluation procedure:</u>
2006/42/EC	Machinery Directive	Appendix VIII
2006/95/EC	Low Voltage Directive	Appendix IV
2004/108/EC	EMC Directive	Appendix II
2000/14/EC	Noise Emissions Directive	Appendix V

Applied (harmonised) norms:

EN ISO 12100:2010	EN 12158-1:2000+A1:2010
EN 60204-1/32:2008	EN 12159:2012

EC type testing procedure:		
Type testing certification		NL 10-400-1001-068-10
European notified body	0400	LIFTINSTITUUT Buikslotermeerplein 381 1020 MA Amsterdam

This EC conformity declaration becomes null and void if any changes are made to the aforementioned machine that have not been authorised by the manufacturer.
Authorised representative for technical documentation is the signatory.

Asbach-Bäumenheim 2011-01-03

Johann Sailer
(Managing Director)

Table of contents:

Chapter	page
COPY OF THE EC CONFORMITY DECLARATION.....	2
1 PREFACE	6
2 SAFETY	7
2.1 EXPLANATIONS OF SYMBOLS AND NOTES.....	7
2.1.1 <i>Health and safety symbol</i>	7
2.1.2 <i>Attention note</i>	7
2.1.3 <i>Note</i>	7
2.2 GENERAL SAFETY	7
2.3 OPERATIONAL SAFETY	8
2.3.1 <i>Inspection procedures</i>	9
2.3.2 <i>Safety notes for assembly, operation and transport</i>	10
2.3.3 <i>Safety instructions for maintenance</i>	10
2.4 REASONS FOR ISSUING AN OPERATING MANUAL.....	11
2.5 EMPLOYEES HAVE TO BE INFORMED ABOUT:.....	11
3 INTENDED USE AND SCOPE OF APPLICATION	12
3.1 INTENDED USE IMPLIES.....	15
3.2 CONSEQUENCES OF NON-INTENDED USE OF THE EQUIPMENT	15
3.3 REQUIREMENTS ON THE ASSEMBLY PERSONNEL	15
3.4 OPERATING PERSONNEL	15
4 TECHNICAL DATA	16
4.1 ANCHORING AND SPACE REQUIREMENT.....	17
4.2 ANCHORING FORCES.....	20
4.2.1 <i>Anchoring forces for a hoist car <u>with loading ramp</u>, hoist assembled in front of a scaffold</i>	20
4.2.2 <i>Anchoring forces for a hoist car <u>without loading ramp</u>, hoist assembled in front of a scaffold</i>	20
4.2.3 <i>Anchoring forces for a hoist car <u>with loading ramp</u>, hoist assembled directly in front of a wall</i>	21
4.2.4 <i>Anchoring forces for a car <u>without loading ramp</u>, hoist assembled directly in front of a wall</i>	22
4.2.5 <i>European wind map</i>	23
4.2.6 <i>Stiffener tubes</i>	23
4.3 SUMMARY OF MANDATORY SIGNS	24
4.4 EQUIPMENT	27
4.4.1 <i>GEDA MULTILIFT P6 STANDARD</i>	27
4.4.2 <i>GEDA MULTILIFT P6 COMFORT</i>	28
4.4.3 <i>Drive unit</i>	29
4.4.4 <i>Hoist car or assembly control unit</i>	29
4.4.5 <i>Control unit on the ground</i>	30
4.4.6 <i>Control unit at the landing level safety gate</i>	31
4.4.7 <i>Switch cabinet for the cable box</i>	32
4.4.8 <i>Sliding door</i>	33
4.4.9 <i>Triangular wrench</i>	33
4.4.10 <i>Hoist car lightning</i>	34
4.4.11 <i>Hatch in the roof</i>	34
4.4.12 <i>Interphone system for emergency</i>	35
4.4.13 <i>Operating time indicator</i>	35
4.5 ACCESSORY COMPONENTS	36
4.5.1 <i>Base enclosure (height = 1.10m) for the GEDA-MULTILIFT P6 Standard</i>	36
4.5.2 <i>Underrun protection</i>	37
4.5.3 <i>Drop test control</i>	37
5 REQUIREMENTS ON THE PLACE OF INSTALLATION.....	39
5.1 FOUNDATION/ PRESSURE ON THE GROUND.....	39
5.2 ELECTRICAL CONNECTION (ON-SITE).....	39
6 TRANSPORT	40
6.1 LOADING AND UNLOADING THE MACHINE	40
7 INSTALLATION.....	41
7.1 SAFETY NOTES	41

7.2	INSTALLING THE BASE UNIT	42
7.3	EXTENDING THE MAST ELEMENTS AND ANCHORING THEM TO THE BUILDING	43
7.3.1	<i>Assembling the mast sections up to a height of 4m</i>	<i>43</i>
7.3.2	<i>Mast anchoring for assembly with a landing level sliding door.....</i>	<i>49</i>
7.3.3	<i>Mast anchoring for assembly with a landing level double door</i>	<i>50</i>
7.3.4	<i>Putting on mast elements at heights between 4m and 10m.....</i>	<i>51</i>
7.3.5	<i>Assembling the mast elements above a height of 10m</i>	<i>51</i>
7.3.6	<i>Emergency limit switch bar</i>	<i>52</i>
7.4	SECURING THE LOADING AND UNLOADING POINTS	52
7.5	LANDING LEVEL LIMIT SWITCH BAR	54
7.6	INSPECTION AFTER ASSEMBLY AND BEFORE EACH BEGINNING OF OPERATION.....	55
8	OPERATION	56
8.1	SAFETY NOTES	56
8.1.1	<i>Rules for people travelling in the hoist car</i>	<i>56</i>
8.1.2	<i>Rules for ground personnel.....</i>	<i>56</i>
8.1.3	<i>Rules for loading and unloading the hoist car.....</i>	<i>57</i>
8.2	SAFETY INSPECTIONS	57
8.3	OPERATION	58
8.3.1	<i>Operating the GEDA MULTILIFT P6 STANDARD</i>	<i>58</i>
8.3.1.1	<i>Arriving at a landing level using external control units.....</i>	<i>60</i>
8.3.1.2	<i>Going to a landing level using the control unit in the hoist car.....</i>	<i>62</i>
8.3.2	<i>Operating GEDA MULTILIFT P6 COMFORT</i>	<i>63</i>
8.3.2.1	<i>Making the hoist car go to the landing levels using external control units</i>	<i>65</i>
8.3.2.2	<i>Going to the landing levels using the hoist car's control</i>	<i>67</i>
8.4	SHUTTING DOWN IN CASE OF AN EMERGENCY	68
8.5	INTERRUPTION WORK – AT THE END OF WORK	68
9	DISMANTLING THE MACHINE	68
10	FAULT – CAUSE - REMEDY	69
10.1	DIAGNOSTIC SYSTEM (OPTION)	71
10.2	FAULTS THAT MAY OCCUR DURING OPERATION	72
10.2.1	<i>Power failure or defective motor.....</i>	<i>72</i>
10.2.2	<i>Recovering people locked inside the hoist car</i>	<i>73</i>
10.2.3	<i>The hoist car has gone too high</i>	<i>74</i>
10.2.4	<i>The hoist car has gone too low.....</i>	<i>74</i>
10.2.5	<i>The hoist car is not able to recognise the selected landing level</i>	<i>75</i>
10.2.6	<i>The overload warning device has triggered.....</i>	<i>75</i>
10.3	THE OVERSPEED SAFETY DEVICE HAS TRIGGERED	75
11	MAINTENANCE.....	77
11.1	SETTING MECHANISM	77
11.2	DAILY CLEANING	78
11.3	DAILY CHECKS	78
11.4	WEEKLY INSPECTION/ MAINTENANCE.....	79
11.5	MONTHLY INSPECTION/ MAINTENANCE	79
11.6	QUARTERLY INSPECTION/ MAINTENANCE	80
11.7	ANNUAL MAINTENANCE.....	81
11.8	SERVICING THE HOIST EVERY SIX YEARS	81
11.9	CHECKING THE OVERSPEED SAFETY DEVICE WITHIN THE SCOPE OF REGULAR INSPECTIONS	82
12	REPAIRS	83
13	DISPOSING OF THE MACHINE	84
14	WARRANTY	84
15	APPENDIX FOR THE RESULTS OF REGULAR INSPECTIONS.....	85

List of illustrations:

Fig. 1 Main switch	8
Fig. 2 EMERGENCY-STOP push-button	9
Fig. 3 Vertical distances and spatial requirements for the hoist car without unloading ramp	17
Fig. 4 Space requirements for a hoist car with loading ramp	18
Fig. 5 European wind map.....	23
Fig. 6 MULTILIFT P6 STANDARD	27
Fig. 7 MULTILIFT P6 COMFORT	28
Fig. 8 Drive unit.....	29
Fig. 9 Control unit in the hoist car/ Assembly control unit	29
Fig. 10 Ground control unit	30
Fig. 11 Control unit at the landing level	31
Fig. 12 Switch cabinet of the cable box	32
Fig. 13 Opening and closing the sliding door from outside	33
Fig. 14 Emergency release for the sliding door	33
Fig. 15 Triangular wrench	33
Fig. 16 Hoist car lightening	34
Fig. 17 Hatch in the roof	34
Fig. 18 Interphone system	35
Fig. 19 Operating hours counter	35
Fig. 19 Base enclosure (height = 1.10m)	36
Fig. 20 Element of the base enclosure (height = 1.10m) containing the barrier	36
Fig. 21 Installing the electric module	36
Fig. 22 Underrun protection	37
Fig. 23 Drop test control	37
Fig. 24 Control unit in the hoist car with landing level pre-selection	38
Fig. 25 Take-up points for forklift trucks	40
Fig. 27 Installing the trailing cable holder	42
Fig. 28 Opening the assembly hatch	43
Fig. 29 Opening the assembly guard.....	44
Fig. 30 Putting on a mast element.....	45
Fig. 31 Connecting mast elements	45
Fig. 32 Trailing cable guide	46
Fig. 33 Assembly plank.....	47
Fig. 34 Safety lock	47
Fig. 35 Closed assembly plank.....	47
Fig. 36 Open assembly plank	48
Fig. 37 Mast anchor	49
Fig. 38 Top mast anchoring for overrun and for assembly with landing level double doors	50
Fig. 39 Emergency limit switch bar	52
Fig. 40 Designation of the points of access.....	53
Fig. 41 Positioning the landing level limit switch bar	54
Fig. 42 Opening the barrier.....	60
Fig. 43 Opening the sliding door.....	60
Fig. 44 Closing the sliding door	60
Fig. 45 Opening the swing doors at the landing levels.....	61
Fig. 46 Opening the sliding doors of the landing levels.....	61
Fig. 47 Releasing the motor brake	72
Fig. 48 Safety interlock	73
Fig. 49 Overspeed safety device	76
Fig. 50 Setting mechanism	77
Fig. 51 Lubricating device.....	80
Fig. 52 Filling gun	80
Fig. 53 Plugging in the drop test control unit	82
Fig. 54 Drop test control unit	82

1 Preface

Who should read this assembly and operating manual?

- Assembly and operating personnel working on the machine
- Maintenance personnel for the machine (cleaning/servicing)

What does this assembly and operating manual contain?

In this assembly and operating manual, you will find instructions regarding

- Intended use
- Residual risks
- Safety
- Installation
- Operation
- Troubleshooting
- Customer service

This assembly and operating manual communicates important information that is a prerequisite for working safely and economically with the machine. It is assumed that the machine is equipped with all possible options.

What you should do immediately!

Read this assembly and operating manual carefully before assembly and commissioning, observe all notes and especially the safety instructions.

What is not contained in this assembly and operating manual?

This assembly and operating manual is not a repair manual!

You will not find documents about repair work in this assembly and operating manual

What should be considered when re-selling the machine?

When selling the machine, provide this assembly and operating manual together with the annual inspection entries and replacement parts list to the purchaser.

2 Safety

2.1 Explanations of symbols and notes

2.1.1 Health and safety symbol



This symbol is found next to all safety instructions where there is a risk to life and limb of persons. Observe these instructions and proceed with caution!

2.1.2 Attention note

ATTENTION is found at points where special information or rules and prohibitions regarding damage prevention are given in order to prevent damage to the equipment.

2.1.3 Note

NOTE is found at points where information is given about using the machine economically or instructions are given regarding correct working procedures.

2.2 General safety

The machine has been manufactured according to the current state of technology and is safe to operate. However, due to its work processes, the machine has sections and components that cannot be protected without impairing the function and operating capacity of the unit. Therefore good personal safety practice is required to protect personnel and equipment. Risks are associated with this equipment if it is used improperly by untrained personnel or in a manner for which it was not intended or authorised.

- Prior to carrying out transport, assembly, commissioning, dismantling and maintenance, read and precisely adhere to the machine's assembly and operating manual, as well as to safety instructions!

Read the assembly and operating manual and make sure you have understood it before starting to work on the machine. Afterwards it will be too late!

- The operating manual should be kept accessible in close proximity to the machine.
- Supplementing the assembly and operating manual are the generally valid, legal and other binding provisions for accident prevention and environmental protection respective to the country where the machine is being operated (e.g. wearing personal protective equipment such as head gear, safety shoes, etc.).
- Comply with attached notices and warning signs.

- Always wear close fitting clothing, safety shoes and head gear during work. Do not wear any jewellery such as necklaces and rings. There is a risk of injury from getting caught or being pulled in.
- In the event of an injury or an accident, immediately consult a doctor.



Consequences of not complying with safety instructions

Non-compliance with safety instructions can result in danger both for personnel as well as for the environment and the machine. Non-compliance can lead to the forfeiture of any damage compensation claims.

2.3 Operational safety

- The machine has to be set up and dismantled according to this assembly manual under supervision of an authorized person specified by the contractor.
- Install the hoist so that it is in an exactly vertical and stable position and anchor it to the building.
- Observe the load bearing capacity of the machine.
- Only use the machine in a technically fault-free condition; use it in a safety and risk conscious manner while observing the operating manual.
- Immediately remedy faults that could impair safety.
- Shutdown the machine immediately if there are safety-relevant changes to the unit or its operating behaviour and report the fault to the company management or its representative.
- Do not make any changes, attachments or modifications to the machine. This also applies to the installation and adjustment of safety devices, such as limit switches.
- Do not change, remove, bypass or bridge safety devices.
- Immediately replace damaged or removed notices and warning signs, as well as safety labels.
- When work is interrupted, switch off the machine at the main switch and secure it with a padlock against being switched back on.

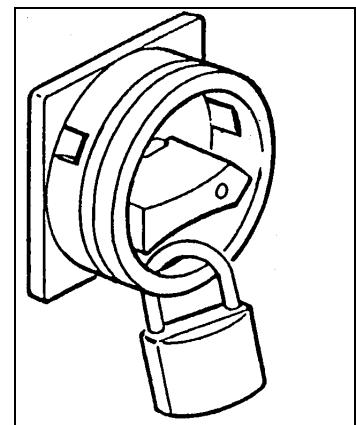

Fig. 1 Main switch

- In situations that present a risk to the operating personnel or the machine, shut down the machine by pressing the EMERGENCY STOP button.
- If wind speeds are >72 km/h (43mph) (\approx wind force 7-8, wind moves trees and impedes pedestrians!) make the hoist car come down to the ground and shut down the hoist.

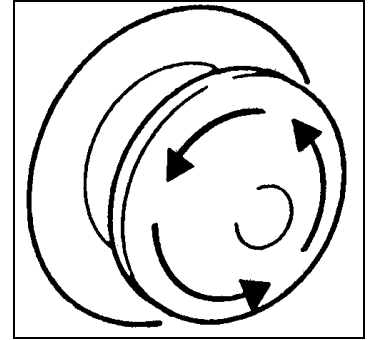

Fig. 2 EMERGENCY-STOP push-button

2.3.1 Inspection procedures

The **GEDA MULTILIFT P6** is a machine in compliance with the EC machinery directive 2006/42/EC. A copy of the conformity declaration is reproduced in this operating manual.

Tests after each installation → see section 7.6

The following tests have already been carried out at the factory:

- Dynamic test with 1.25 useful load.
- Electrical tests according to EN 60204
- Function tests.

Regular inspections:

- Inspections prior to commissioning, regular inspections and intermediate inspections must be carried out according to national regulations.

NOTE

GEDA recommends that you carry out a recurring inspection on an annual basis. In the case of increased use and strain (e.g. multi-shift operation), carry out inspections at shorter intervals.

- The results of the regular inspection must be written down in the appendix of this operating manual.

2.3.2 Safety notes for assembly, operation and transport

- Before starting work at the place of use, acquaint yourself with the working environment, e.g. obstacles in the work and traffic area, load bearing capacity of the ground and necessary safeguarding of the installation site from public transport.
- Only load and transport equipment that has been carefully dismantled, packed and securely lashed down.
- Categorically secure the machine against unauthorised use (disconnect from power)!
- Position the load securely on the car. Any material that could slip or fall must be secured.
- Do not stand or work beneath the car!
- Do not place any objects under the car.
- Position loads evenly in the car, observe max. load bearing capacity.
- Store material at a minimum safety distance of 50cm from moving parts of the machine.
- Any accompanying persons must comply with instructions given by the operating person; in particular, they must not step over material that is being carried in the car.
- Check for externally recognisable damage, noises and defects. Report any changes or malfunctions detected immediately to the company management or its authorised representative. If necessary, shutdown and secure the machine immediately.

2.3.3 Safety instructions for maintenance

- Disconnect the machine (e.g. remove the mains plug) before carrying out maintenance work.
- The car must be secured using appropriate means (setting mechanism) when work is carried out beneath it.
- Only allow servicing and repair work to be carried out by authorised, qualified persons. For example consider also those particular dangers arising from working on electrical systems.
- Properly reinstall all dismantled safety devices once maintenance work has been completed.
- Arbitrary modifications or changes to the machine impair safety and are not permitted.
- Replacement parts must correspond to the technical requirements of the manufacturer.
- Recommendation: Only use original GEDA spare parts.

2.4 Reasons for issuing an operating manual

Operating instructions are rules compiled by a company to ensure safe operational procedures. These refer to binding instructions issued by a company within the context of its management rights. Employees are obliged to follow these instructions in accordance with accident prevention regulations.

The general obligation of the company to create and disseminate operating instructions must be derived from the accident prevention regulation "General provisions".

According to this guideline, the contractor must fulfil the instructions for preventing work-related accidents and must instruct the insured party about risks occurring during their work and the measures for averting said risks. The company can fulfil these requirements by means of operating instructions.

The operating manual provided here must be supplemented by national regulations regarding accident prevention and environmental protection! For example:

EN 60204-1 and EC directive

- 89/655/EEC regarding minimum requirements for safety and health protection for the use of work equipment by employees during work.
- 92/57/EEC regarding minimum requirements for safety and health protection for temporary or non-stationary work sites.
- 90/269/EEC regarding basic safety instructions.

2.5 Employees have to be informed about:

- The potential risks when working with the hoist and the necessary protective measures and codes of conduct including instructions in the case of danger and about first aid.
- Type and scope of regular inspections to ensure a safe working environment (see section 11).
- Maintenance
- Rectification of malfunctions
- Environmental protection
- Safe handling of electrical equipment.
- The user must ensure cleanliness and clarity at the place where the machine is set up by using instructions and checks.
- Responsibilities during set-up and tear-down (assembly/dismantling), operation and maintenance must be clearly defined and regulated by the operating company, and must be adhered to by all persons so that no unclear competencies arise with regard to safety.
- The operator must accept responsibility to operate the machine only in a fault-free condition. He/she is obliged to report immediately to his/her supervisor any changes occurring to the equipment that affect safety.
- Comply with attached notices and warning signs.
- The operator has to ensure that no unauthorised persons are present on or near the machine.

3 Intended use and scope of application



The machine is a construction hoist intended for provisional use on construction sites for transporting material and/ or a maximum of 12 persons, who have to be able to exit the car installed and secured landing points.

- The MULTILIFT P6 is intended for provisional use on construction sites for transporting persons and material. It may only be used on construction sites by instructed personnel who can exit the car at installed and secured landing points.
- Landing level safety gates are absolutely necessary even when using it purely as a material hoist. The hoist may only be operated once these landing level safety gates have been installed!
- The maximum number of persons is limited to 12.
- The Multilift P12 is controlled by relays (24 m/min.) or by a frequency converter (max. 40 m/min.).
- Operation is only permitted at wind speeds of up to 72 km/s (20 m/sec. \approx wind force 7 - 8). If wind forces are higher, the car must be lowered to ground level and work must be stopped!
- The machine is equipped with an overload device which switches off the travel movement in both directions when the load bearing capacity is exceeded; a red warning lamp lights up on the car control.

The Multilift can be operated with a low base enclosure (Standard) and with a 2.5 m high enclosure (Comfort).

MULTILIFT P6 STANDARD

- Base enclosure, height = 1.10m
- The hoist can be controlled from the hoist car, the ground station and from the levels.

**Exceptions:**

- During assembly only the car control is active. All other control points are switched off, only the Emergency-Off-stop buttons remain functioning.
 - During operation, control from the higher landing levels is only possible above the 2m safety zone. From these control points, you can only make the hoist car go down to 2.0m above the ground.
 - Within the safety zone you can only make the hoist car move using the control units in the car or on the ground. As the enclosure is only of limited height, a warning sound that lasts for about 3 seconds is emitted before the hoist car starts its movement. An underrun protection is installed beneath the car which stops the car if it comes into contact with obstacles when moving down.
- The MULTILIFT P6 STANDARD can be installed at a certain distance from or directly in front of a wall. This depends on what kind of sliding doors (with or without ramps) are used on the side pointing towards the landing levels. The kind of doors also decides whether landing level safety gates with sliding gates or with swing doors have to be used.

MULTILIFT P6 COMFORT

- The hoist is equipped with a base enclosure (height = 2.50m).
- You can control the hoist from the hoist car, from the ground station and from the landing levels.

Exception:

- During assembly only the control unit in the hoist car is active. All other control points are switched off, only the Emergency-stop buttons remain functioning.
During operation you can also control the hoist using the operator station on the ground or the control units at the upper landing levels without any restrictions.

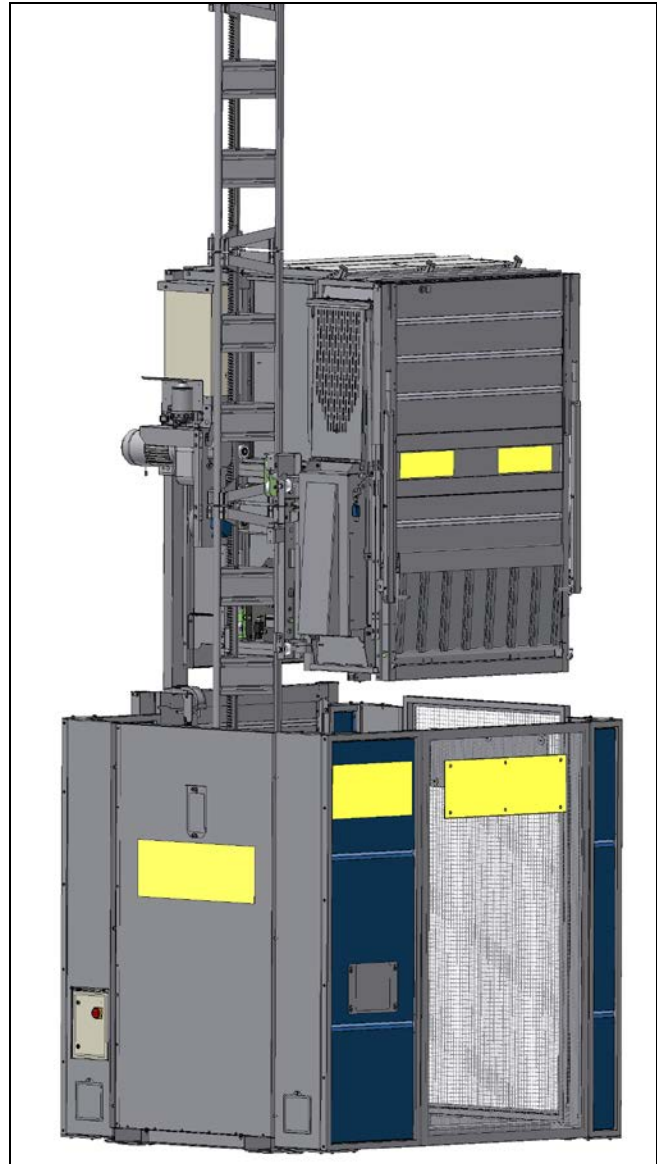

- The MULTILIFT P6 STANDARD can be installed at a certain distance from or directly in front of a wall. This depends on what kind of sliding doors (with or without ramps) are used on the side pointing towards the landing levels. The kind of doors also decides whether landing level safety gates with sliding gates or with swing doors have to be used.

3.1 Intended use implies

- that only persons having received the necessary instructions (platform conductors) control the hoist when it is used for the transport of people.
- that the assembly, operation and maintenance provisions (assembly and operating manual) provided by the manufacturer are complied with.
- that foreseeable misconduct of other persons is taken into consideration.
- that national operational guidelines are observed.

3.2 Consequences of non-intended use of the equipment

- Danger to life and limb of the user or a third party.
- Damage to the machine and/or other tangible assets.

3.3 Requirements on the assembly personnel

The hoist must only be assembled, operated and maintained by qualified personnel. These people have to be able to guarantee to handle the machine appropriately due to the training they have received, their knowledge and their practical experience. They have to be appointed by the contractor to carry out installation, dismantling and maintenance.

3.4 Operating personnel

The machine may only be operated by persons who, based on their training, knowledge and practical experience, can guarantee to handle the machine correctly. These persons must

- have been appointed by the contractor.
- have been appropriately trained and instructed concerning possible risks.
- be familiar with the assembly and operating manual.
- observe national regulations.

Residual risks



Despite of having undertaken all possible precautions, there are still some potential risks, which are not always too obvious, such as

- Injuries due to uncoordinated work methods
- Hazards from a malfunction in the control system
- Hazards from working on the electrical system
- Hazards from damage to the load carrying device
- Hazards due to an improperly secured load falling down
- Hazards due to high wind speeds (> 72 km/h - 43 mph)
- Hazards from entering and leaving the hoist car.

4 Technical data

GEDA® MULTILIFT P6	
- Drive output:	3.0/6.1kW 400V/50Hz
- Current consumption of the drives:	7.5/13.8Amp.
- Max. starter current:	ca. 60Amp.
- Traction force of the drive unit:	13000N
- Lifting speed:	24m/min (12m/min. for the STANDARD hoist within the safety zone)
- Triggering speed of the overspeed safety device	approx. 30m/min.
- Load bearing capacity:	650kg / 6 persons
- Load bearing capacity during assembly:	250kg / 500kg (see chapter 7.3)
- Maximum assembly height:	100m
- Anchoring distance:	max. 6m
- Maximum mast projection:	1,75m
- Interval between the cable guides:	max. 6m
- Length of one mast section:	1,5m
- Weight of one mast section:	44.4kg
- Screw tightening torque:	150Nm
- Space requirements (width x depth x height) with open loading ramp and door	approx. 2.24m x 2.42m x 2.75m
- Weights: Base unit with hoist car and 50m trailing cable 25m cable	max. 2200kg + 19kg
- max. dynamic pressure: during assembly during operation when shut down	q = 100N/m ² (45km/h) q = 250N/m ² (72km/h) EN12158-1 (hoist car on the ground)
- horizontal force for loading and unloading	Reduced to 7,5% of the load bearing capacity as the loading ramp bears on the landing level
- Noise emission values (measuring point in the car)	<78dB (A)

- The machine is equipped with an overload device which switches off the movement of the hoist car in both directions when the load capacity is exceeded; consequently a red warning lamp lights up on the car control.

4.1 Anchoring and space requirement

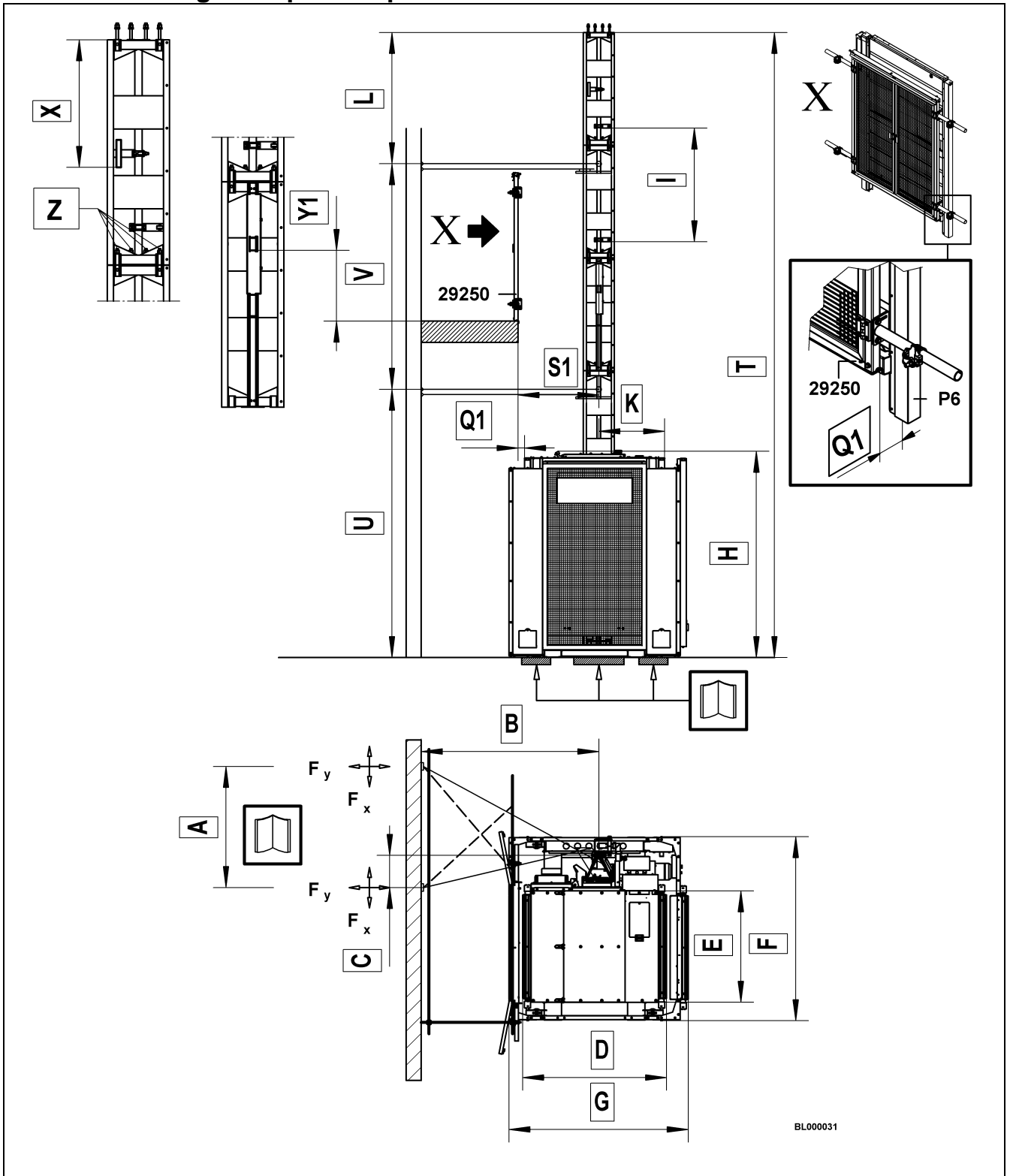

Fig. 3 Vertical distances and spatial requirements for the hoist car without unloading ramp

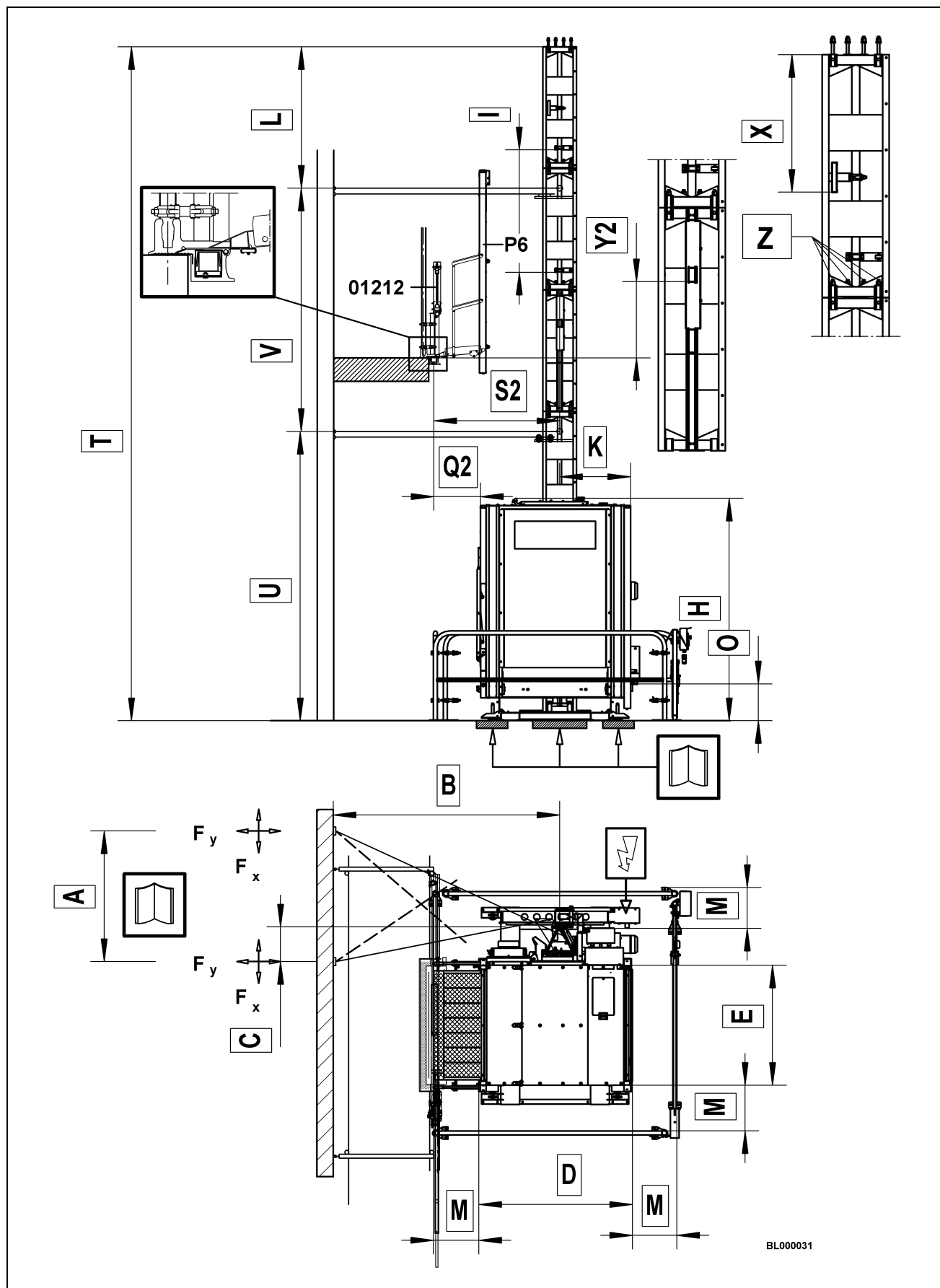

Fig. 4 Space requirements for a hoist car with loading ramp

Table for Fig. 3 and Fig. 4

A	Interval between the wall anchors	see chapter 4.2.1 to 4.2.4
B	Distance center circular tube of the mast to the wall	see chapter 4.2.1 to 4.2.3
C	Inclination of the fixing tube	See chapter 4.2.1 to 4.2.4
D	Useful depth of the hoist car	1.88m / 6.17 ft
E	Useful width of the hoist car	1.47m / 4.82 ft
F	Width of the base unit	2.43m / 7.97 ft
G	Depth of the base unit (ramp not unfolded)	2.36m / 7.74 ft
H	Height of the base unit (sliding doors closed)	2.72m / 8.92 ft
I	Maximum interval between the cable guides	< 6m / 19.68 ft
K	Distance center circular tube to sliding door loading side "A"	0.87m / 2.85 ft
L	Maximum length of projecting mast length	< 1.75m / 5.74 ft
M	Minimum distance of movable parts of the hoist car to the low enclosure (height =1.1m, STANDARD)	0.5m / 1.64 ft
O	Loading height on the ground	0.45m / 1.48 ft
Q1	Hoist car sliding door to center of the cross tube of the landing level safety gate sliding door	0.085m / 0.28 ft
Q2	Sliding door of the hoist car to the center of the cross tube of the landing level safety gate	0.57m / 1.87 ft
S1	Distance from the center of the circular tube of the mast to the center of the landing level swing door.	1.07m / 3.51 ft
S2	Distance center of the circular tube of the mast to center cross tube of the landing level sliding door	1.54m / 5.05 ft
T	Maximum assembly height	≤ 100m / 328 ft
U	Height of the first mast anchoring	≤ 4m / 13.12 ft
V	Vertical distance between further mast anchorings	≤ 6m / 19.68 ft
X	Distance from the emergency-off limit switch bracket to the end of the mast	> 1.25m / 4.1 ft
Y1	Distance landing level floor to landing level limit switch bracket (for landing level swing door)	0.28m / 0.92 ft
Y2	Distance landing level floor to landing level limit switch bracket (for landing level sliding gate)	0.265m / 0.87 ft
Z	Tightening torque of the mast connecting bolts	150Nm / 110 lbf.ft

4.2 Anchoring forces

The anchoring forces can be found in the following tables depending on the respective location (see wind map), assembly height and assembly situation.

If the assembly geometry shown in Fig. 3 and Fig. 4 is changed, the corresponding anchoring forces have to be requested.

4.2.1 Anchoring forces for a hoist car with loading ramp, hoist assembled in front of a scaffold

Anchoring interval = 6m

Maximum load bearing capacity = 650kg

A = 2.50m; B = 2.77m; C = 0.38m

	Highest mast anchoring Length of the projecting mast end 1.75m		Other anchorings or highest mast anchoring without projection	
wind region	F_x	F_y	F_x	F_y
A / B / C / D / E	4.87 kN	6.55 kN	3.99 kN	5.22 kN

The values indicated in the table apply to each mast anchoring tube.

4.2.2 Anchoring forces for a hoist car without loading ramp, hoist assembled in front of a scaffold

Anchoring interval = 6m

Maximum load bearing capacity = 650kg

A = 2.50m; B = 2.18m; C = 0.28m

	Highest mast anchoring Length of the projecting mast end 1,75m		Other anchorings or highest mast anchoring without projection	
wind region	F_x	F_y	F_x	F_y
A / B / C / D / E	5.09 kN	5.61 kN	4.16 kN	4.06 kN

The values indicated in the table apply to each mast anchoring tube.

4.2.3 Anchoring forces for a hoist car with loading ramp, hoist assembled directly in front of a wall

NOTE

If a hoist car with a loading ramp is installed directly in front of a wall, the mast anchoring has to be anchored to the wall (to the ground or to the ceiling). The horizontal distance (A) between the fixing plates is too big to install the fixing plate of the bracing tube from the assembly plank.

Interval between the anchorings = 6m
 Maximum load bearing capacity = 650kg

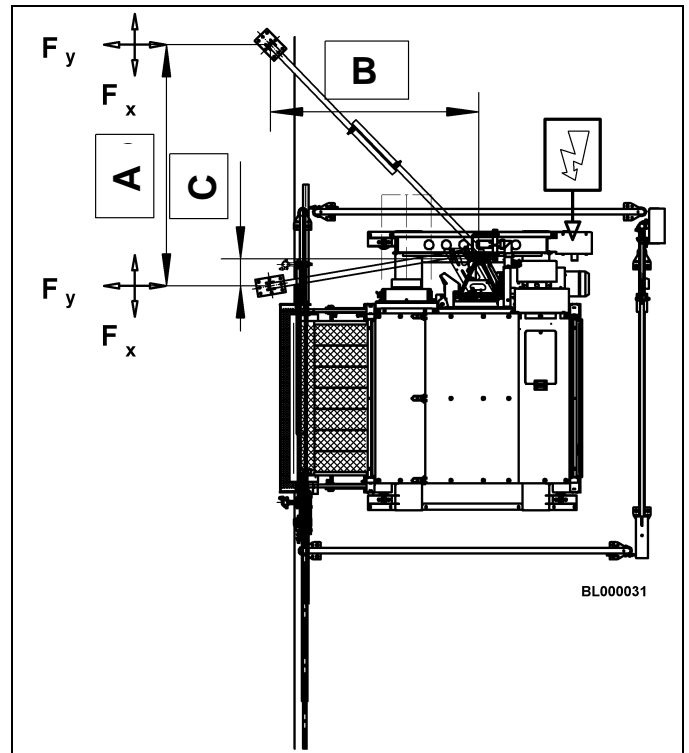

A = 2.09m; B = 1.80m; C = 0.23m

wind region	Highest mast anchoring Length of the projecting mast end 1,75m		Other anchorings or highest mast anchoring without projection	
	F_x	F_y	F_x	F_y
A / B / C / D / E	4.87 kN	6.55 kN	3.99 kN	5.22 kN

The values indicated in the table apply to each mast anchoring tube.

4.2.4 Anchoring forces for a car without loading ramp, hoist assembled directly in front of a wall

NOTE

Assembly directly in front of a wall is only possible if the swing doors are installed onto the projecting parts of the wall (balconies). The foot section of the base unit reaches approx. 15cm below the wall projection balcony).

B = distance center circular tube of the mast to wall projection (front side of the balcony).

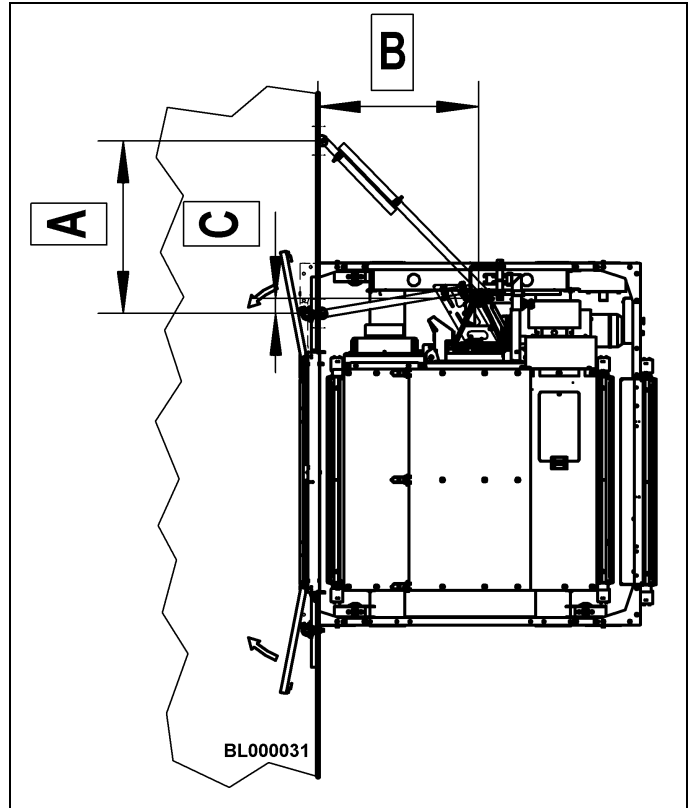

Interval between the anchorings = 6m
 Maximum load bearing capacity = 650kg

A = 1.15m; B = 1.07m; C = 0.10m

wind region	Highest mast anchoring Length of the projecting mast end 1,75m		Other anchorings or highest mast anchoring without projection	
	F_x	F_y	F_x	F_y
A / B / C / D / E	5.09 kN	5.61 kN	4.16 kN	4.06 kN

The values indicated in the table apply to each mast anchoring tube.

4.2.5 European wind map



Assembly height H [m]	Wind pressures for geographical regions [N/m ²]			
	A/B	C	D	E
0<H≤10	544	741	968	1225
10<H≤20	627	853	1114	1410
20<H≤50	757	1031	1347	1704
50<H≤100	879	1196	1562	1977
100<H≤150	960	1306	1706	2159

Fig. 5 European wind map

4.2.6 Stiffener tubes

In certain assembly situations (very long distances to the fixing points), it may be necessary to use stiffener tubes in addition to the anchoring tubes to prevent these from bending.

The table is only valid for the indicated materials and dimensions of the tubes.

- Smooth, one-piece steel tubes without cant. Ø 48,3 x 3,25 – St 37-2 DIN 2448 or DIN 2458

Buckling length	Allowed pressure
100 cm	52640 N
150 cm	38960 N
200 cm	26720 N
250 cm	18660 N
300 cm	13580 N
350 cm	10280 N
400 cm	8030 N
450 cm	6460 N
500 cm	5290 N
550 cm	4410 N
600 cm	3730 N
650 cm	3200 N
700 cm	2770 N
750 cm	2420 N



Use the anchoring forces indicated in the tables to calculate the actual pressure occurring in the tube.

If the indicated pressures for the respective buckling lengths are exceeded, you have to implement further actions to prevent the tubes from bending.

4.3 Summary of mandatory signs

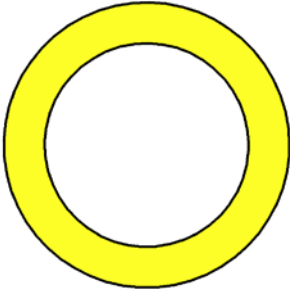
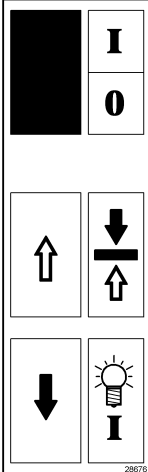
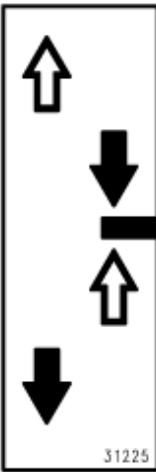
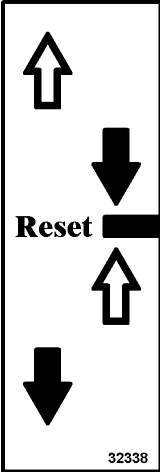
<p>Item no. 33696 (assembly guard)</p>	<p>Item no. 14657 (hoist car control)</p>	<p>Item no: 17597 (enclosure, height 1.1m)</p>
<p>Item no. 28659 (Fork lift receptacles)</p>	<p>Item no.:31322 (hoist car)</p>	
<p>Item no.: 05242 (switch cabinets)</p>	<p>Item no.: 15431 (overspeed safety device)</p>	<p>Item no. 22326 (sliding doors)</p>
<p>Item no. 28663 (interphone system)</p>	<p>Item no. 31554 (cable box)</p>	

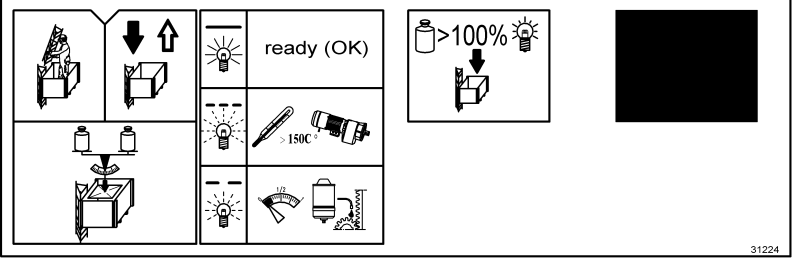
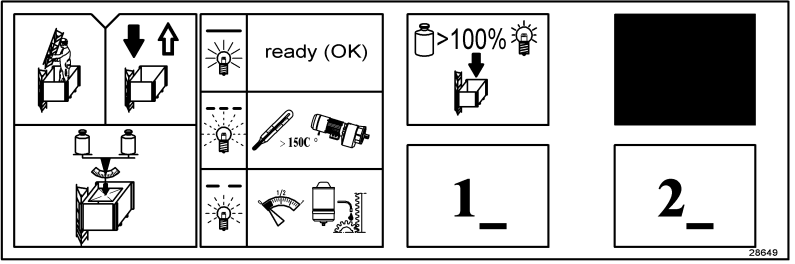
			
<p>Item no. 29906 (Landing level control unit)</p>	<p>Item no. 28676 (control unit on the ground)</p>	<p>Item no.: 31225 (landing level control unit)</p>	<p>Item no. 32338 (hoist car control unit)</p>

<div style="border: 1px solid black; padding: 5px; margin-bottom: 5px;">  <p style="text-align: right; font-size: small;">31224</p> </div> <p>Item no.31224 (hoist car control unit)</p>	<p>9</p> <p>8</p> <p>7</p> <p>6</p> <p>5</p> <p>4</p> <p>3</p> <p>2</p> <p>↑ 1 ↓</p> <p>Reset</p> <p>0 ↑</p> <p>↓</p> <p>Start</p> <p style="text-align: right; font-size: x-small;">32318</p>												
<div style="border: 1px solid black; padding: 5px; margin-bottom: 5px;">  <p style="text-align: right; font-size: x-small;">28649</p> </div> <p>Item no.. 28649 for option with landing level pre-selection (hoist car control unit)</p>													
<div style="border: 1px solid black; padding: 10px; text-align: center;"> <p style="font-size: 2em; margin: 0;">MAX. 650kg / MAX. 6</p>  </div> <p>Item no. 30828 (assembly guard and enclosure)</p>													
<div style="border: 1px solid black; padding: 5px;"> <p style="font-size: 1.5em; margin: 0;">GEDA®</p> <p style="font-size: x-small; margin: 0;">Dechentreiter GmbH & Co. KG D-86663 Asbach - Bäumenheim</p> <div style="text-align: right; font-size: 2em; margin: 5px 0;">CE</div> <table border="1" style="width: 100%; border-collapse: collapse; margin-top: 5px;"> <tr> <td style="padding: 2px;">Art. Nr.</td> <td colspan="3"></td> </tr> <tr> <td style="padding: 2px;">H =</td> <td style="width: 20px;">m</td> <td style="width: 20px;">m</td> <td style="width: 20px;">m</td> </tr> <tr> <td style="padding: 2px;">L =</td> <td style="width: 20px;">m</td> <td style="width: 20px;">m</td> <td style="width: 20px;">m</td> </tr> </table> </div> <p style="margin-top: 10px;">Item no.32053 (cable box)</p>	Art. Nr.				H =	m	m	m	L =	m	m	m	<p>Item no. 32318 for option with landing level pre-selection (hoist car control unit)</p>
Art. Nr.													
H =	m	m	m										
L =	m	m	m										

POSITION
position

32899

Item no. 32899 (control unit in the hoist car)

FAHRZIEL
destination

32899

Item no. 32899 (control unit in the hoist car)

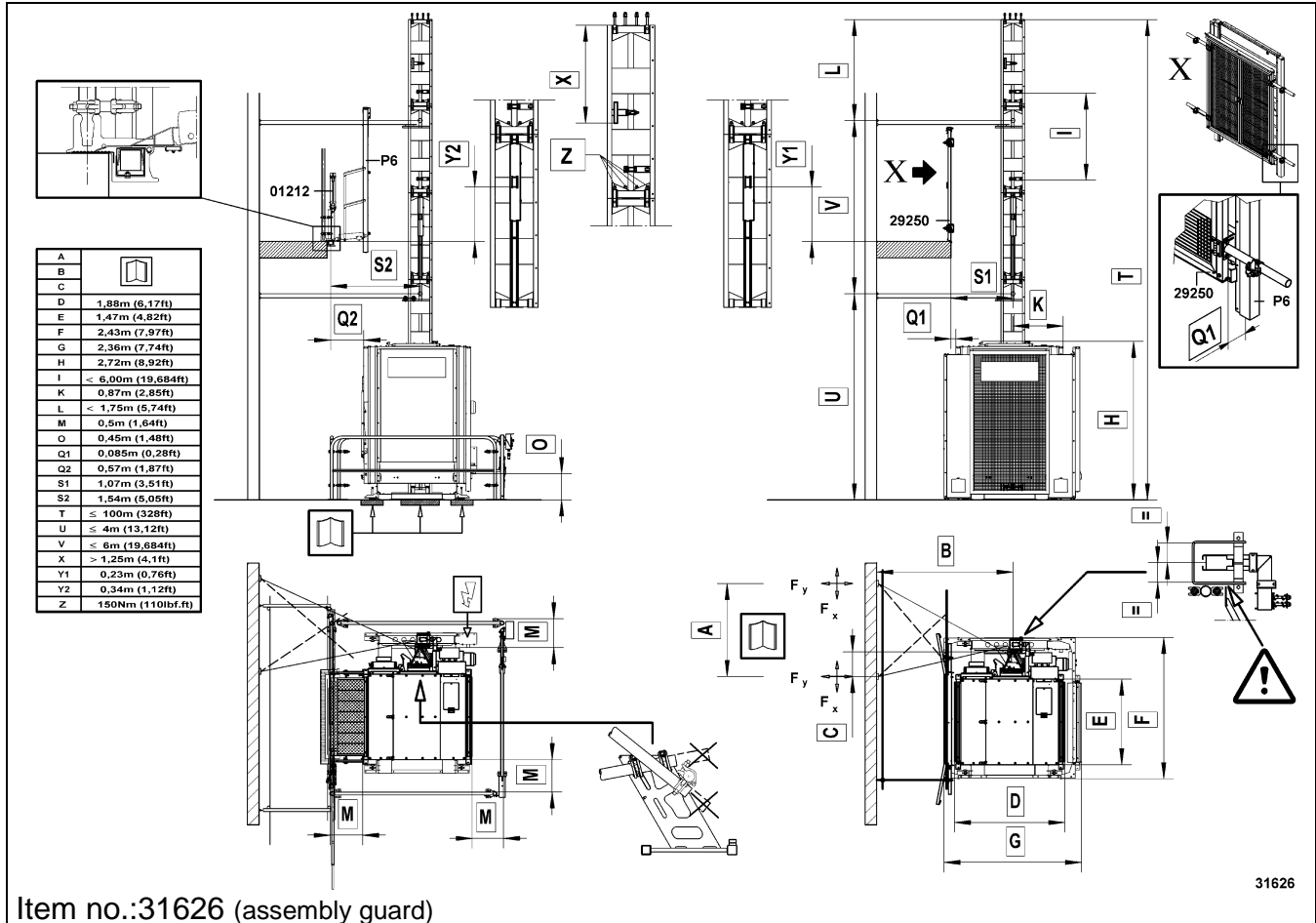

Item no.:31626 (assembly guard)

31626

GEDA®		30829
Dechentreiter GmbH & Co. KG D-86663 Asbach - Bäumenheim		CE
GEDA® MULTILIFT P6		
Jahr/year:	F-Nr./S-No.:	
Tragfähigkeit / load capacity: 6 Pers. max.		kg
Masthöhe / mast height:	max. 100 m	
Hubgeschwindigkeit / speed:	24m/min.	
2m - Sicherheitsbereich / 2m-safety area:	12m/min.	
Gewicht der Grundeinheit / weight of base unit: max.		kg

Type plate (control unit of the hoist car)

GEDA®		
Dechentreiter GmbH & Co. KG D-86663 Asbach - Bäumenheim		CE
Fangvorrichtung Overspeed safety device		FV18
Baujahr:	20	
Year of construction:		
Fabr.Nr.:		
Serial no.:		
Bremsweg max.:	0,6 m	
Braking distance max.:	2 feet	
Bremslast max.:	1800 kg	
Braking force max.:	3968 pound	
Auslösegeschwindigkeit max.:		30 m/min

Type plate (overspeed safety device)

4.4 Equipment

4.4.1 GEDA MULTILIFT P6 STANDARD

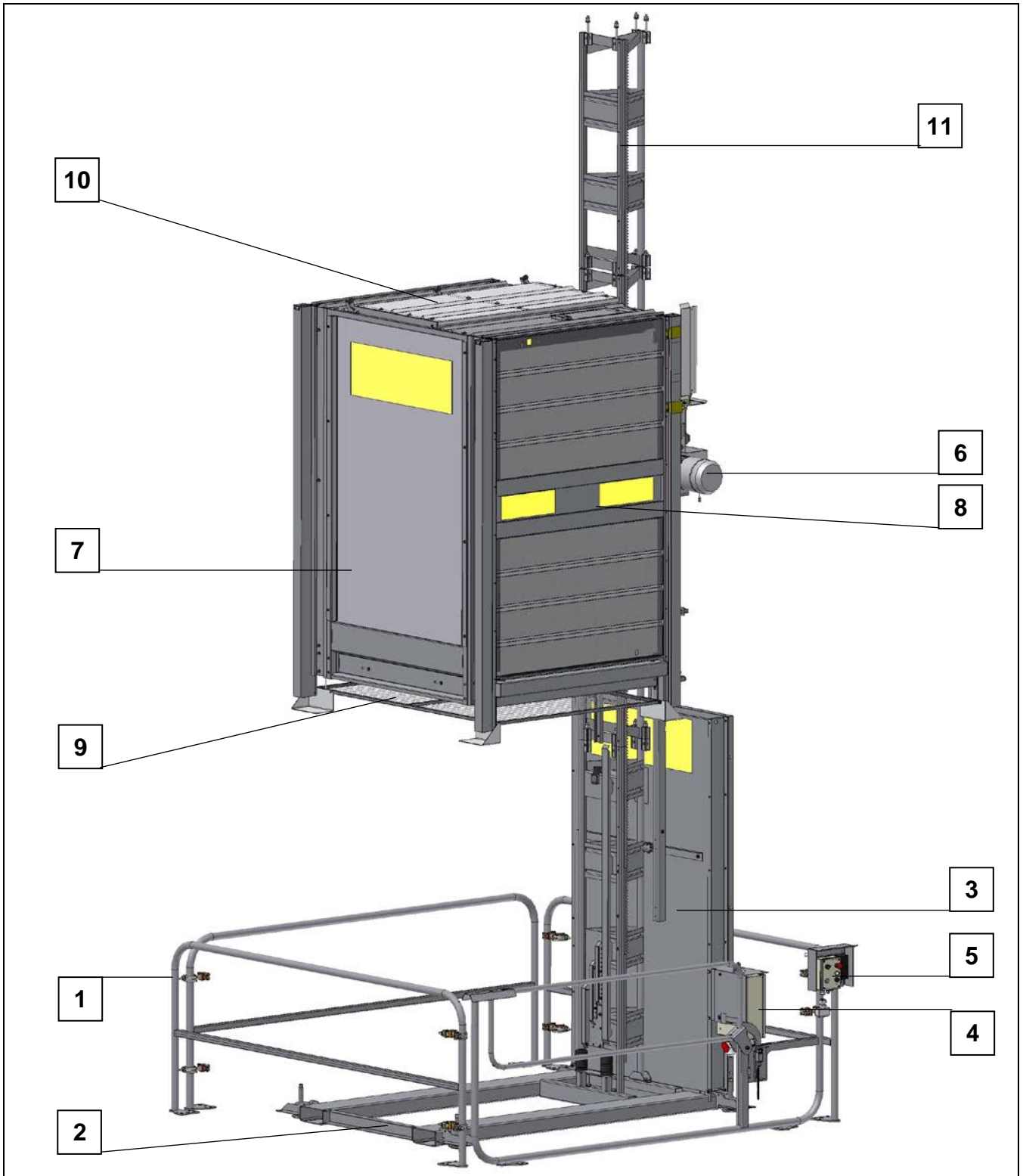

Fig. 6 MULTILIFT P6 STANDARD

1 = Enclosure (height = 1.10m) with barrier

2 = Foot section with base mast

3 = cable box

4 = switch box for cable box

5 = ground control unit

6 = drive unit

7 = hoist car

8 = sliding door

9 = underrun protection

10 = assembly flap

11 = mast extension

4.4.2 GEDA MULTILIFT P6 COMFORT

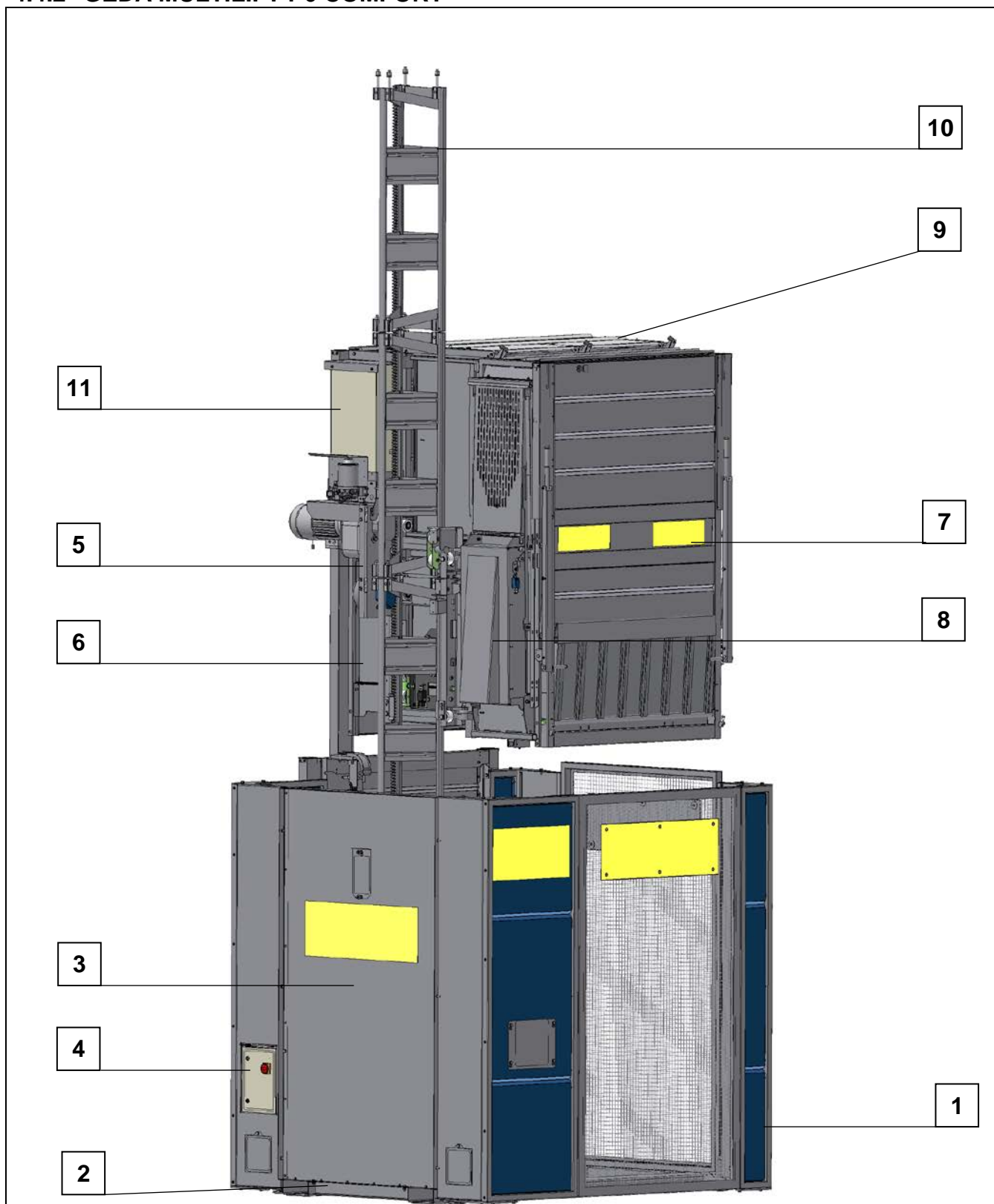

Fig. 7 MULTILIFT P6 COMFORT

- | | | |
|---|---|------------------------------------|
| 1 = enclosure (height = 2.50m)
with sliding door | 5 = trolley with drive and
overspeed safety device | 9 = assembly flap |
| 2 = foot section with base mast | 6 = hoist car | 10 = mast extension |
| 3 = cable box | 7 = sliding door (with ramp) | 11 = control unit in the hoist car |
| 4 = switch box for cable box | 8 = assembly plank | 12 = drive unit |

4.4.3 Drive unit

- 1 = drive motor
- 2 = switch box of the control unit in the hoist car
- 3 = automatic greasing device

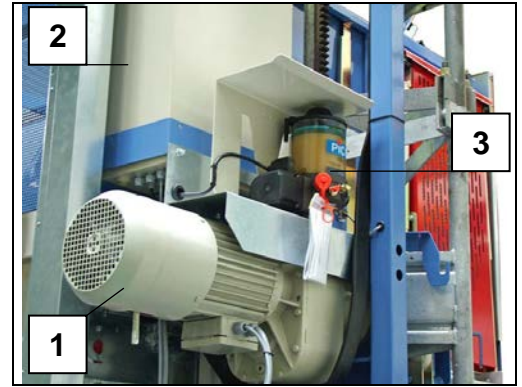

Fig. 8 Drive unit

4.4.4 Hoist car or assembly control unit

- 1 = EMERGENCY-OFF button
- 2 = key operated switch
 - position left = assembly
(only the control unit in the hoist car is active)
 - position right = operation
(control units in the hoist car, on the ground and at the landing levels are active)
- 3 = control lamp ready for operation
 - continuous light → hoist ready for operation
 - slow flashing light → lack of grease for the greasing device
 - fast flashing light → excess temperature of the motor
- 4 = overload control lamp
- 5 = UP button
- 6 = DOWN button
- 7 = level stop button (the hoist car stops at the next landing level)
- 13 = level indicator
- 14 = working socket 230V/50Hz/16A
- 15 = Diagnostic system

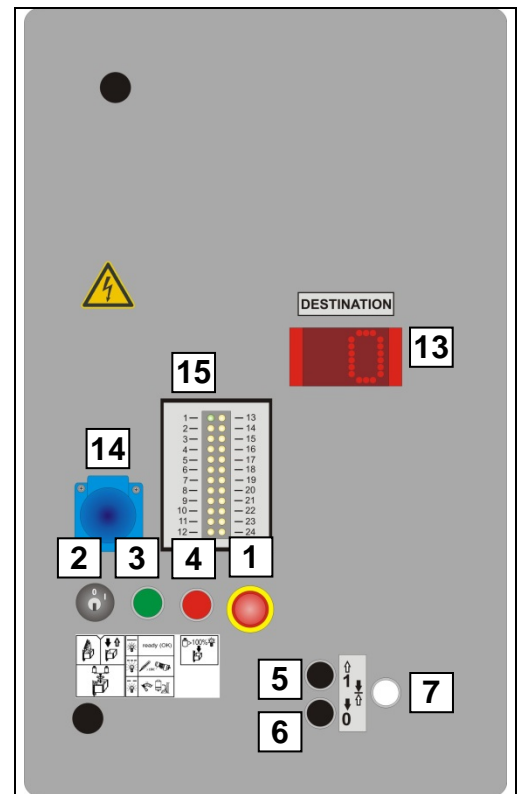

Fig. 9 Control unit in the hoist car/ Assembly control unit

NOTE

- The approximate lifting speed of the hoist car during assembly is 12m/min.
- The approximate lifting speed of the hoist car during operation is 24m/min. (12m/min for the STANDARD edition within the safety zone).



The car control must be disconnected from the mains (unplug trailing cable) before opening the switch cabinet door!

4.4.5 Control unit on the ground

- The limit switch of the sliding door monitor (enclosure) or barrier is plugged into the black 7-pole plug socket (8).
- The supply line (9) [16-pole plug] for the ground control is plugged into the cable box switch cabinet (see chapter 4.4.7).

- 1 = EMERGENCY-OFF button
 2 = UP button (for going up to the highest landing level)
 3 = DOWN button (for going down to the ground station)
 4 = level Stop button (the hoist car stops at the next landing level)
 5 = Key operated switch for the hoist ON/OFF
 6 = control lamp ready for operation
 7 = interphone

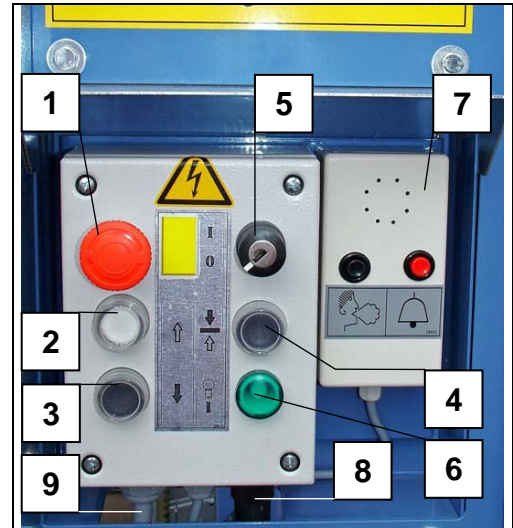

Fig. 10 Ground control unit

NOTE

Using the **MULTILIFT P12 STANDARD** you have to press the UP button (2) and the DOWN button (3) below the 2m safety height.

4.4.6 Control unit at the landing level safety gate

Using the **MULTILIFT P6 STANDARD** you can only use the UP (2) and DOWN buttons (3) above the 2m safety height.

Using the **MULTILIFT P6 COMFORT** you can make the hoist car move down to the ground station using the landing level control units.

The car can be stopped at any time using the EMERGENCY STOP button (1).

- 1 = EMERGENCY-STOP button (does not engage)
- 2 = UP button
- 3 = DOWN button
- 4 = landing level stop button (the hoist car will stop at the next level)

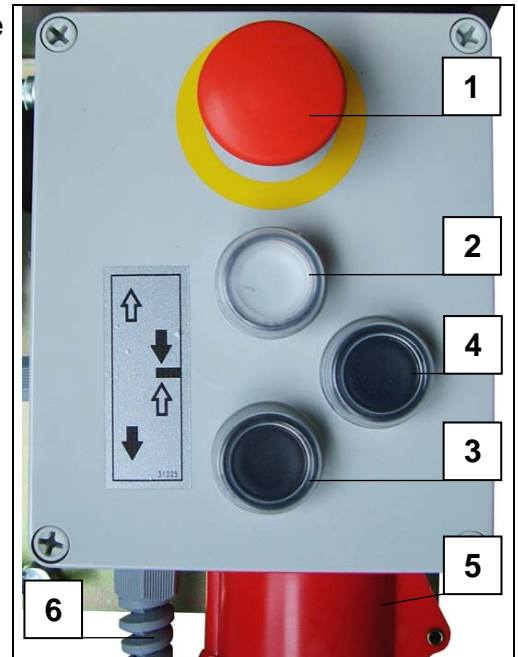

Fig. 11 Control unit at the landing level

- The supply line (6) [7-pole plug, red] from the first level gate switch cabinet is plugged into the cable box switch cabinet (see chapter 4.4.7).
- If there are several landing levels with control units, plug the supply line (6) [7-pole plug, red] of the second level into the control unit of the level below.

NOTE

Change the dummy plug from the cable box switch cabinet to the uppermost landing level control unit switch cabinet.

4.4.7 Switch cabinet for the cable box

NOTE

Plug in the plug of the trailing cable below the switch box in the hoist car.



- Connect the mains supply line (5) to the mains (building site main cabinet).
- Connect the plug supply line for ground control to the 16-pole socket (2).
- Plug the supply line for the first level control unit into the 7-pole red socket (3).
- Connect the limit switch cable of the setting mechanism to the 4-pole circular socket (4).
- Turn on the main switch.

1 = main switch

- 2 = socket (ground control unit)
 3 = socket (red) for landing level safety gate
 (or dummy plug during assembly)
 4 = socket for setting mechanism
 5 = mains supply line

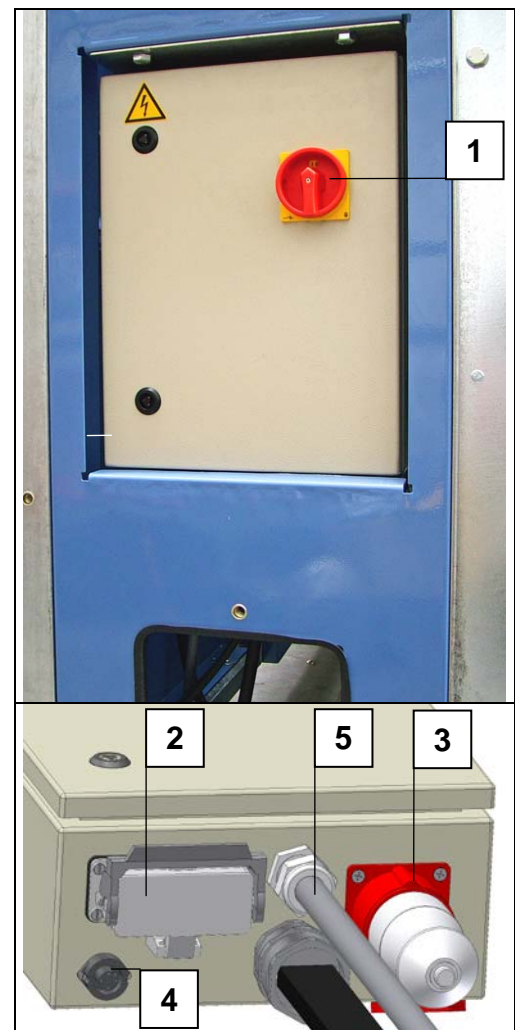

Fig. 12 Switch cabinet of the cable box

4.4.8 Sliding door

It must only be possible to open the sliding door of the hoist car if the car (stopped by the landing level limit switch) stops in front of a landing level safety gate or if it is on the ground (stopped by the "down" limit switch). It is only possible to open the sliding door of the hoist car that is in front of the sliding door or barrier of the base enclosure or in front of a landing level safety gate.

Open the sliding door (1)

- Push the sliding door up until it stops using the central handle grip (2).

NOTE

If you use a sliding door with a ramp, the ramp automatically folds down when the sliding door is opened.

Closing the sliding door from outside

- Using the lower handle grip (3), pull the sliding door down until it is completely closed.

NOTE

If you use a sliding door with a ramp, the ramp automatically folds up when the sliding door is closed.

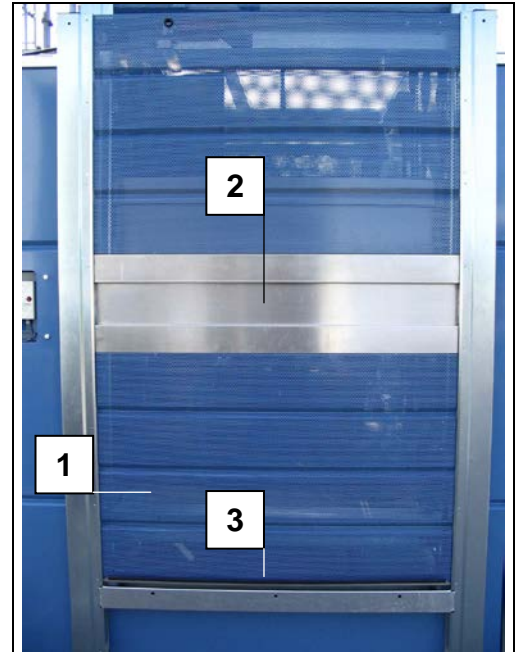

Fig. 13 Opening and closing the sliding door from outside

Emergency interlock release

- To activate the emergency interlock release, insert the triangular wrench through the bore on the outside of the sliding door and turn to the right.
- Turn the wrench back after interlock release has been carried out.

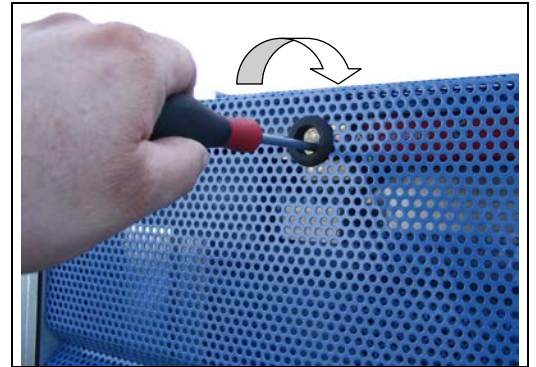

Fig. 14 Emergency release for the sliding door

4.4.9 Triangular wrench

The triangular wrench is in the switch cabinet for the cable box.

The triangular wrench can be used to open or close the switch cabinets, the emergency interlock release on the sliding doors and the safety interlock on the assembly bridge.



Fig. 15 Triangular wrench

4.4.10 Hoist car lightening

- The car lighting (1) is always illuminated as long as the main switch is turned on.

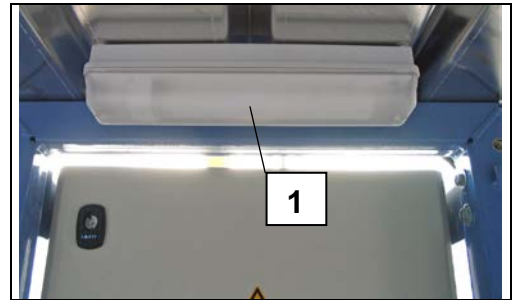

Fig. 16 Hoist car lightening

4.4.11 Hatch in the roof

You can open a hatch in the roof of the hoist car in order to transport materials that are longer than the car (e.g. tubes).

- Loosen the screw (2) and remove it.
- Pivot up the cover.

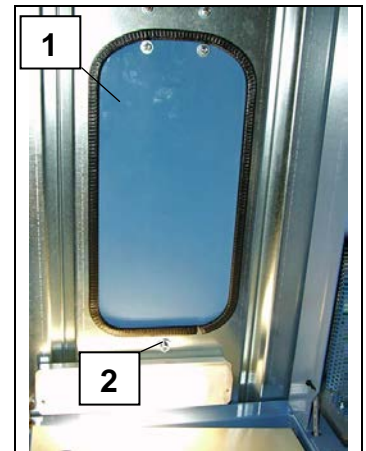

Fig. 17 Hatch in the roof

4.4.12 Interphone system for emergency

Basics

If people are locked in the hoist car, they can contact the personnel on the ground using the interphone system.

- The interphone system establishes contact with the ground station.
- The emergency system consists of the talking set next to the switch box of the ground control unit and the talking set next to the hoist car control unit in the hoist car.
- The interphone system uses the mains power supply when the base unit is connected to the power supply. If there is a power failure an internal battery provides power for operation.
- There is a call button (red) and a talk button (black) at each talking set.

Establishing communication

- An acoustic call signal is transmitted to the other end by pressing the red call button (1).
- The connection to the other person is established by pressing the black speak button (2).
- In order to hear the other person speak you must release your own speak button. The person on the other end must hold the talk button pressed for as long as he is speaking.

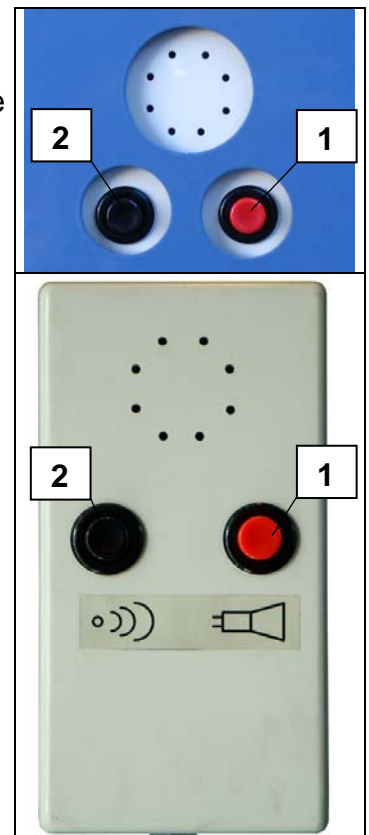

Fig. 18 Interphone system

4.4.13 Operating time indicator

An operating hours counter (1) can be installed in the trolley switch box to record the operating hours (motor operating time)!

NOTE

The switch box must be opened to read the counter.

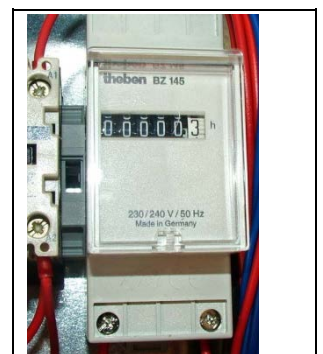

Fig. 19 Operating hours counter

4.5 Accessory components

4.5.1 Base enclosure (height = 1.10m) for the GEDA-MULTILIFT P6 Standard

- The four sided base enclosure consists of 3 parts of equal length and one element with a barrier, which is screwed at the ends by means of scaffold couplings.

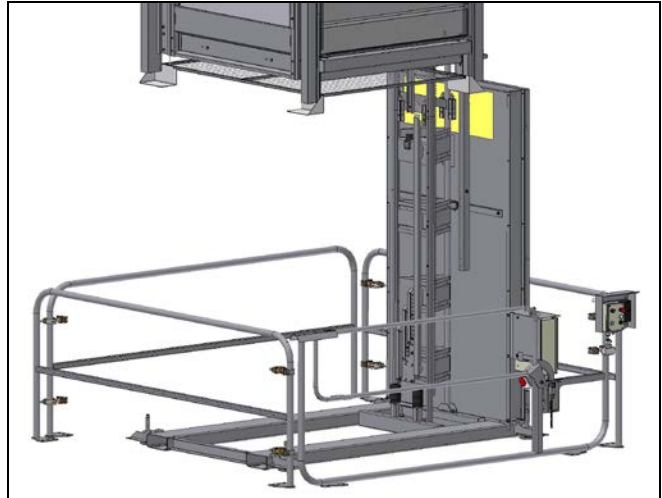

Fig. 20 Base enclosure (height = 1.10m)

- Install the element containing the barrier to the side of the access. You can choose to install the barrier that it opens to the left or to the right.

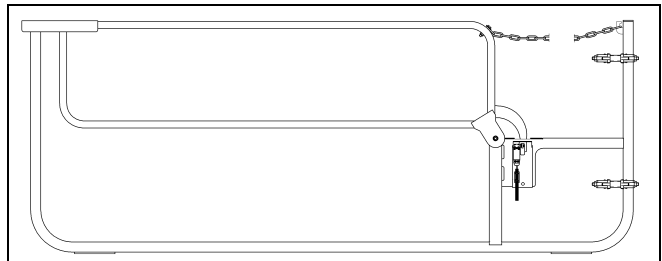

Fig. 21 Element of the base enclosure (height = 1.10m) containing the barrier

- Mount the receptacle (1) for the ground control unit to the lateral element of the enclosure using a scaffold coupling.
- Hinge the ground control unit with the interphone system to the receptacle (1).
- Connect the supply cable for the ground control unit (with 10 pole plug) to the switch cabinet of the cable box.
- Insert limit switch with retaining plate (4) on the hinge of the barrier.
- Push retaining plate (3) up and tighten with the wing bolt.
- Connect the limit switch with retaining plate (4) to the ground control.

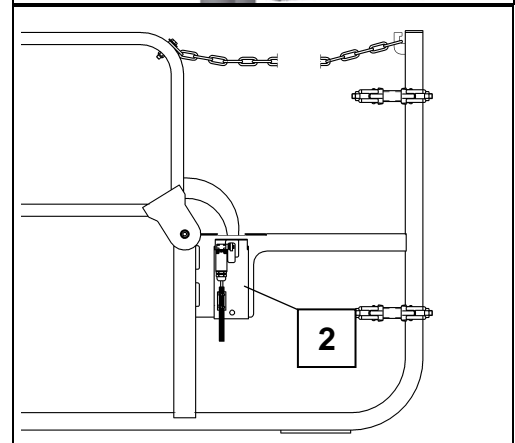
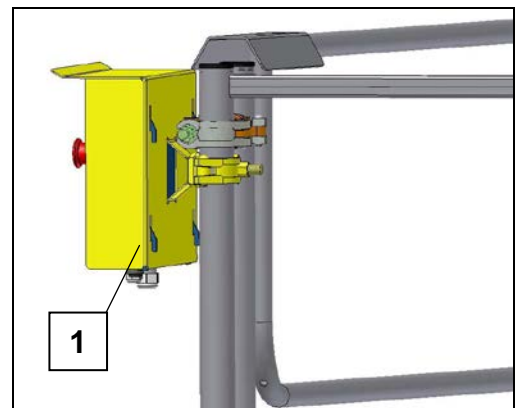

Fig. 22 Installing the electric module

4.5.2 Underrun protection

If the car collides with obstacles the car, the sliding carriage and the drive may be considerably damaged.

For additional protection, you can add the underrun protection (1) to the hoist car



Fig. 23 Underrun protection

NOTE

If the underrun protection (1) is buckled, control is interrupted by a limit switch, which makes it impossible to make the platform move.

4.5.3 Drop test control

1 = EMERGENCY-OFF button

2 = button „brake release“ (in order to check the functioning of the overspeed safety device)

3 = UP button (for going up and releasing the hoist car)

4 = DOWN button

NOTE

You must not use the drop test control for operating or assembling the hoist. This control unit is only intended to be used for the drop test or for release if the hoist cage is in a position that is too low.

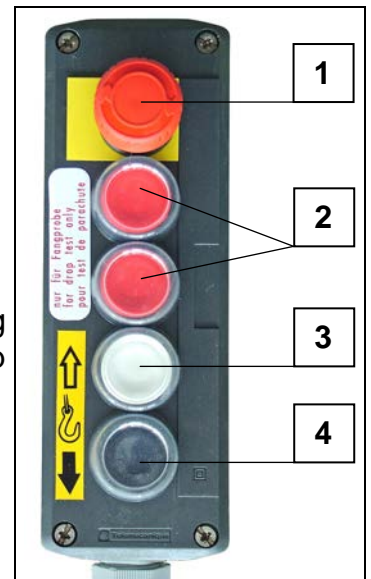

Fig. 24 Drop test control

Hoist car or assembly control with landing level pre-selection (option)

The MULTILIFT P6 COMFORT version can be equipped with a landing level pre-selection control unit.

- 1 = EMERGENCY-OFF button
- 2 = key operated switch
 - left position = assembly
(only the control in the hoist car is active)
 - right position = operation
(the control in the hoist car, the ground control and the controls at the landing levels are active)
- 3 = control lamp ready for operation
 - continuous light → the hoist is ready for operation
 - slow flashing light → lubricating device is lacking grease
 - fast flashing light → excess motor temperature
→ excess braking resistance temperature
- 4 = control lamp for overload
- 5 = button for landing level pre-selection for level 1
[UP button during assembly]
- 6 = button for landing level pre-selection for level 0
[DOWN button during assembly]

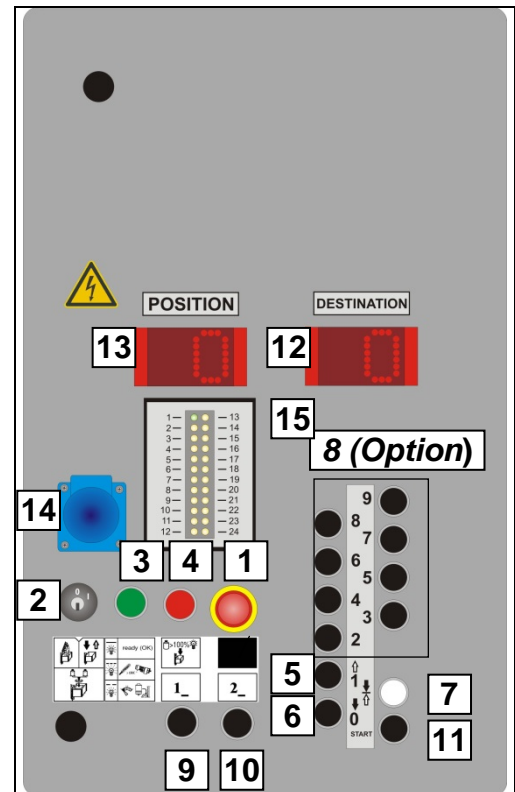

Fig. 25 Control unit in the hoist car with landing level pre-selection

- 7 = landing level stop button (the hoist car stops at the next level)
- 8 = landing level pre-selection buttons for landing levels 2 to 9
- 9 = landing level pre-selection button for landing levels 10 to 19 (level 10 + one of the landing level buttons 1 to 9)
- 10 = landing level pre-selection button for landing levels 20 to 29 (level 20 + one of the landing level buttons 1 to 9)
- 11 = start button after level selection

- 12 = display for landing level pre-selection
- 13 = landing level indicator
- 14 = working socket 230V/50Hz/16A
- 15 = Diagnostic system (Option)

5 Requirements on the place of installation

5.1 Foundation/ pressure on the ground

- The foundation must be horizontal and have sufficient load bearing capacity.
- Compaction of the subsoil must be carried out according to the **floor load [kN/m²]** (see assembly height).
- Depending on the assembly height, wooden planks or steel sheeting, for example, can be used as load distributing base supports.
- The total weight (see table) of the Multilift and of the mast sections is transferred into the subsoil via the foot section support.

Mass per mast (completely assembled)	48 kg	Load bearing capacity of the device	650 kg
Length of one mast	1.5 m		
Height of the base unit	2.75 m		
Maximum empty weight of the machine	2200 kg		
Base area without base support (0.5m x 0.5m)	0.25 m ²		

Assembly height in m	10	20	30	40	50	60	70	80	90	100
Total weight (kg)	3580	3900	4290	4660	4975	5360	5730	6070	6440	6810
Pressure onto the ground (kN/m²)	144	156	172	187	199	215	230	243	258	273

Total weight of the Multilift; (complete with anchorings and cable guides)

5.2 Electrical connection (on-site)

A building site main cabinet (IEC 60364-7-704) with 400V/ and a supply point fuse protection with min. 3 x 16A slow-to-blow fusing is required on site.

- Connect the mains supply cable (3m) from the hoist to the building site main cabinet (plug CEE 5x16A, 6h, red with phase inverter).
- A rubber hose cable of at least **5 x 2.5mm²** is required (see accessories) in order to prevent the motor from voltage drop and loss of power.

6 Transport



Have the hoist transported by experienced and qualified persons. (For weight of the basic unit see section 5).

Inspection upon receiving the hoist

- Check the shipment for transport damage and for completeness according to the purchase order.
- Immediately inform the freight carrier (hauling company) and dealer if there are any damages due to the transport of the machine.

6.1 Loading and unloading the machine

Loading and unloading the machine is carried out with the help of a

- Forklift truck.
 - Forklift take-up points are integrated in the foot section of the base unit.

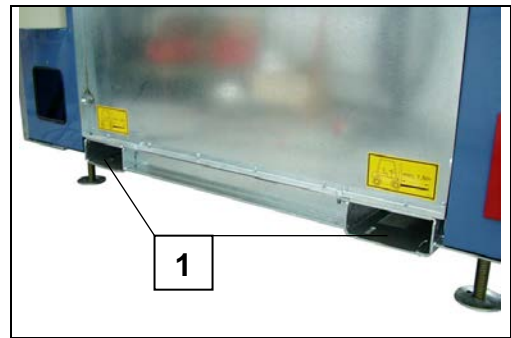
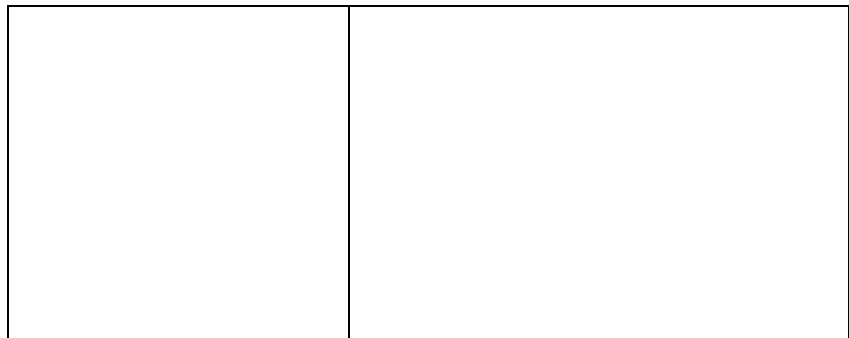

Fig. 26 Take-up points for forklift trucks

ATTENTION

Make sure that the forks of the forklift truck are of sufficient length (observe the sign).

- crane.
 - Mount the crane lug (2) to the base unit.
 - Hang in the crane hook (4) at the load suspension ring (3).and lift.
 - Having used the crane, you have to remove the lug from the base mast again.



Weight of the base unit with enclosure: 2200kg.

ATTENTION

Do not fix the chain suspension directly to the mast.

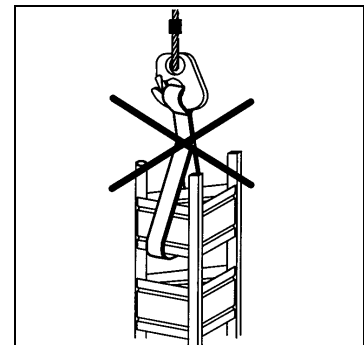

7 Installation



The GEDA- MULTILIFT P6 has to be assembled in accordance with the assembly and operating manual. Assembly has to be supervised by an authorized person specified by the contractor

Assembly personnel see chapter 3.3.

7.1 Safety notes

- Make sure you become acquainted with the on-site working environment, e.g. obstacles in the working and traffic areas, load bearing capacity of the ground, necessary barriers between the construction site and public areas.
- Block of the danger zone of the **GEDA MULTILIFT P6 STANDARD**.
- Make sure that the danger zone at the lower loading point is cordoned off (base enclosure).
- Nobody must stay beneath the hoist car.
- Wind speed during assembly must not exceed 45 km/h (= wind force 5-6).
- National accident prevention regulations from the health and safety executive office and all applicable laws and guidelines must be complied with.
- You have to install original GEDA landing level safety gates to all loading points above a height of 2.0m to prevent people from falling down.
- Observe the load bearing capacity of the hoist.
- If the red overload warning light on the car control lights up, the car is overloaded. - Immediately reduce the loading weight. In this case control is interrupted until the warning light is turned off.
- While assembling the mast you may only make the hoist car go up on the projecting mast for 5.5m beyond the highest mast anchoring. If there is only one mast anchoring has been installed, the maximum load is 250kg. If two or more mast anchorings have been installed, the maximum load is 500kg.
- Make sure that the masonry can bear the anchoring forces. A construction expert has to make out if the building is suitable for anchoring forces of this kind. The inspection results will also determine whether anchor plugs or through bolts will have to be used.

7.2 Installing the base unit

NOTE

If the base unit is not connected to the mains voltage, the sliding doors (of the enclosure and of the hoist car) can only be opened if they are unlocked one after the other with the triangular wrench (see chapter 4.4.8).

- The trailing cable holder is provided and installed by the manufacturer. You may only have to install it yourself if it has been removed for transport reasons.
- Screw the trailing cable holder (4) to the trolley.
- Connect the plug to the socket below the switch box of the control unit in the hoist car and secure with a mounting clip.

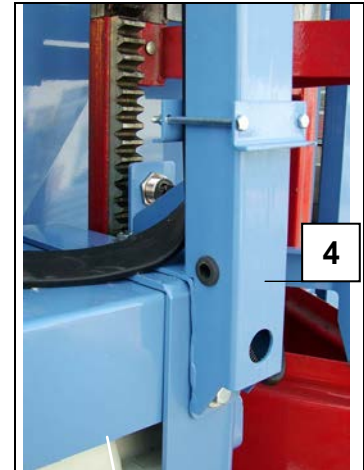

Fig. 28 Installing the trailing cable holder

- The machine may only be installed and used in a vertical position! The base unit must be aligned at right-angles to the building or the scaffolding.
- Put the support points of the base unit (support plates of the spindles and especially the foot section support beneath the mast) onto load distributing and even base supports. Observe the load bearing capacity of the ground.
- Align the base unit according to the specifications in 4.1 and according to the assembly scheme.
- Install the first mast anchor at a height of 4m.

NOTE

The foot section must be secured against shifting at a minimum of 2 of the spindle support plates.

ATTENTION

The foot section must be underpinned beneath the mast over an area of 0.5m x 0.5m (0.25m²), as the spindles are merely used for adjustment, not for transferring forces from the mast sections.

- Vertically align the base mast from the beginning using a spirit level. Check the vertical alignment of each mast element that is added.
- Observe minimum safety distances of 50cm to moving parts of the machine.
- After the main switched has been turned on, a green control light must be illuminated at the ground control and at the hoist car control, which shows that the hoist is ready for operation.
- If the control lamp lights up, look up chapter 10.

- You have to open the hatch in the roof to put on mast elements.
- Take the opening rod out of the central profile of the assembly flap and peg it to the central boreholes (3) of the profile to open the flap.

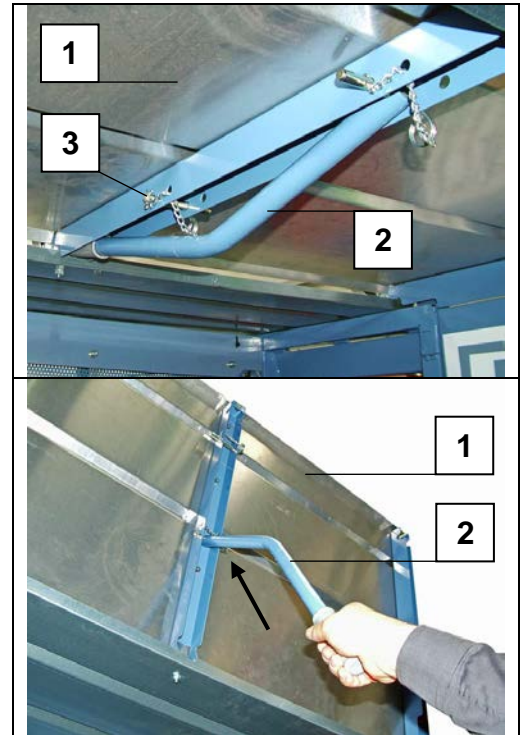

- Open the assembly hatch upwards using the opening rod.

NOTE

On completion of mast assembly, the open assembly flap must be closed again.

Fig. 29 Opening the assembly hatch

7.3 Extending the mast elements and anchoring them to the building

If the device is put up in front of a scaffold, it has to be anchored to the building.

NOTE

It may also be anchored directly to the scaffolding if the scaffold has been designed to bear this additional load (see anchoring forces).

7.3.1 Assembling the mast sections up to a height of 4m

ATTENTION

Vertically align the base mast from the beginning using a spirit level. Check the vertical alignment of each mast element that is added.



Please observe:

- The assembly engineers move up in the hoist car. The hoist is operated using the control unit in the hoist car.
- At the beginning of assembly with only one mast anchoring installed, the maximum load bearing capacity is 250kg until a second mast anchoring is installed at a height of about 10m.

Assembly is carried out from the hoist car, from the assembly plank and from the scaffold (in case there is one).

At the beginning the hoist car is on the ground:

- Depending on the model, open the sliding door or the base enclosure barrier.
- Open the hoist car's sliding door.
- Load the car with mast sections, parts for mast anchoring and tools (**max. 250kg**).
- Close the sliding door or the barrier of the base enclosure.
- Close the sliding door of the hoist car from the inside.
- Turn the key for the assembly of the MULTILIFT in the key operated switch of the hoist car control to position "assembly" (=to the left).

NOTE

First close any open sliding doors and lowered assembly guards as they interrupt the control function.



Before making the hoist car move up, make sure that the base unit is standing safely.

- Press the UP button (at the control unit in the hoist car) and go up in the hoist car until the proximity switch at the end of the mast has stopped upward movement.

NOTE

The assembly guard can only be opened if the assembly plank is open.

- Use the handle to slightly lift the assembly guard (1). Pull forward and lower.



Fig. 30 Opening the assembly guard

- Put the 1.5m mast element (2) onto the base mast (3) with the eye screws pointing upward.

NOTE

The guideways on the rectangular tubes of the mast allow for the mast to be hinged. Two assembly engineers can swivel it up until it engages into the guidings.

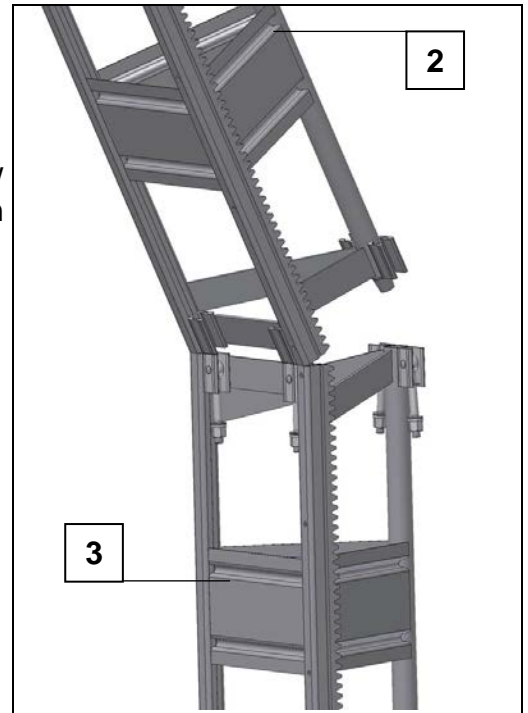

Fig. 31 Putting on a mast element

- Push up the four eye screws (4) and tighten. The screw tightening torque is **150 Nm**.

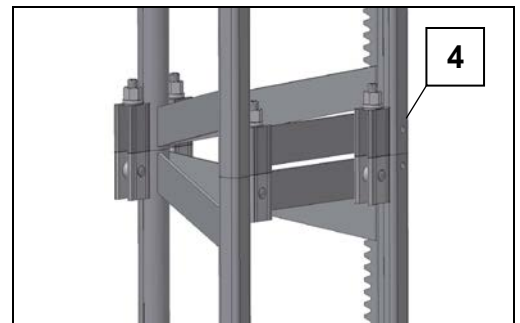
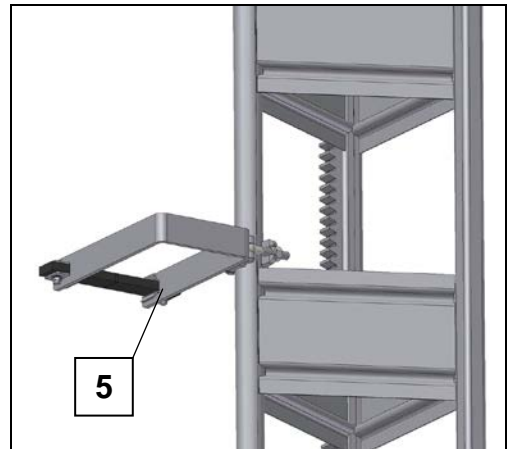

Fig. 32 Connecting mast elements

Trailing cable guide

Trailing cable guides must be installed to ensure that the trailing cable runs freely into the cable box. The more acute the wind force at the location of the machine, the shorter the distances between the trailing cable guides must be. **Max. distance: 6 m.**

- Install the **first** trailing cable guide (5) at a distance of about 1m from the upper edge of the cable box.



- Fix the trailing cable guide to the circular tube of the mast at right angles using rubber clips and align it centrally to the cable holder at the trolley (at a distance of approx. 20 mm from the vertical rectangular tube of the cable holder).

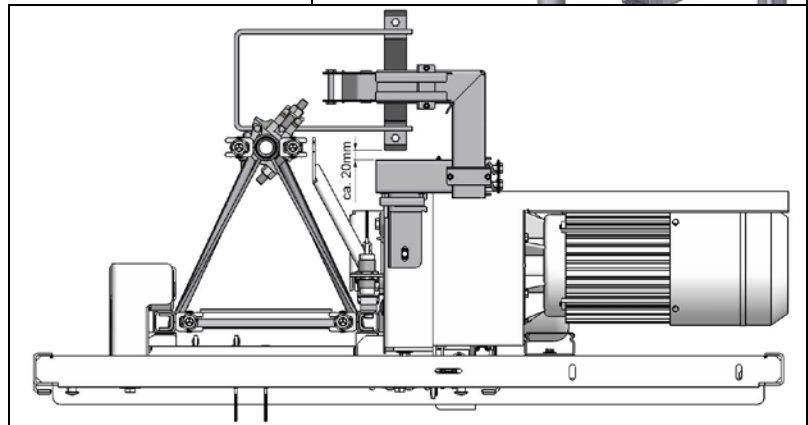

Fig. 33 Trailing cable guide

ATTENTION

Risk of collision with the trolley!

- Push up the assembly guard and hinge.
- Press the UP button and go up to the upper end of the mast element that has been installed.
- Put on another mast element and screw.
- Now you can install the first mast anchoring at a height of approx. 4m without having to move further up.

Assembly plank

The assembly plank is a narrow foldable platform. It allows you to assemble the hoist from the hoist car (this is necessary for example if you are in front of a façade without a scaffold being installed to it). The assembly plank may only be used during assembly and dismantling.

Every time before making the hoist move, make sure that the safety latch of the assembly plank has fully engaged (second tooth) and that the lock is completely closed.



Fig. 34 Assembly plank

Unfolding the assembly plank:

- Take the triangular wrench out of the receptacle (see Fig. 15) and put it into the drill hole on the assembly plank.
- Open the safety lock by turning the triangular wrench to the right (clockwise).



Fig. 35 Safety lock

- Take the handle strip (3) of the assembly plank with your right hand and pull it towards yourself. Open the safety latch (2) with your left hand.
- Push the handle strip (3) slowly outwards. With your other hand, take the bracket (1).
- Release the handle strip (3) and lower the assembly bank completely using the bracket (1).

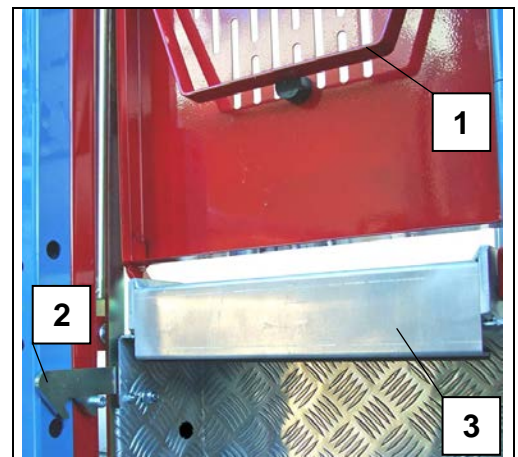

Fig. 36 Closed assembly plank

- As soon as the base pan is lying horizontally you can enter it in order to push the front wall outwards.
- Now, the assembly plank is ready for operation.

NOTE

When the assembly bridge is unfolded, control is interrupted by a limit switch. You cannot make the hoist car move.

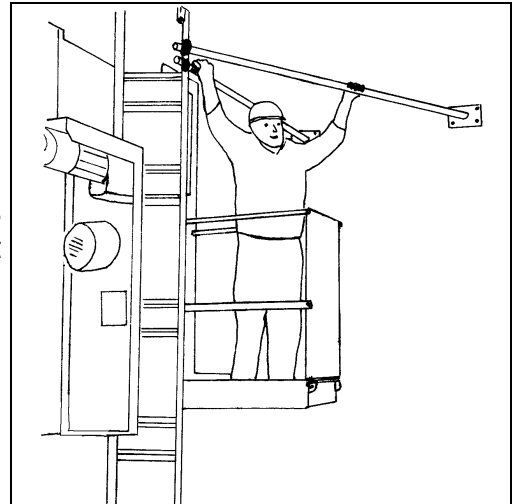

Fig. 37 Open assembly plank



If extension tubes are used, the projecting tube ends must not reach into the travel path/area of the assembly plank - risk of collision!

NOTE

The assembly bridge cannot be unfolded if the fixing tube is mounted at a height lower than 1.6 m above the floor of the car. The car must then be lowered a bit by carefully releasing the drive brake.

Folding up the assembly plank:

- Step on the platform side and grip the bracket (1) to fold up the assembly bridge.
- Pull the front wall towards yourself using the bracket (1) until the base pan of the bridge also starts to move.
- Pull the bridge towards yourself using the handle strip (3) to facilitate the remaining movement until the safety latch (2) engages with its second tooth.
- Close the safety latch's safety interlock by turning the triangular wrench to the left (anticlockwise).

-

NOTE

When the safety lock is open, control is interrupted by a limit switch. The hoist car cannot be made move.

7.3.2 Mast anchoring for assembly with a landing level sliding door

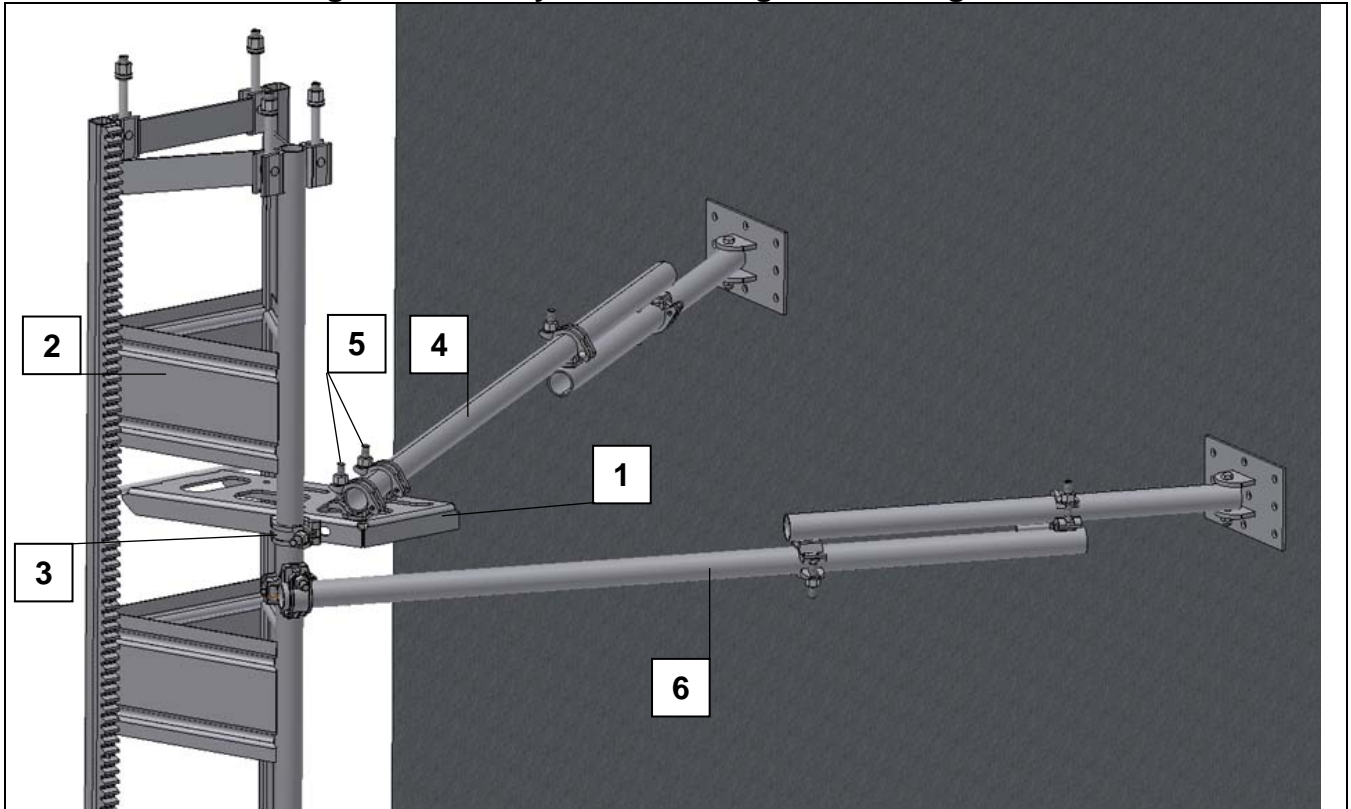

Fig. 38 Mast anchor

- Insert the mast anchor (1) from the front (from your position on the assembly plank) into the mast (2) and fix the scaffold coupling (3) to the circular tube of the mast. (tightening torque **50Nm**).
- Open the scaffold clamps (5) and put in the telescopic tube (4). Close the scaffold clamps only to the extent that you can still move the tube. In order to adjust the angle, loosen the nuts below the scaffold clamps (5) and move one of them within the long hole.
- Tighten all 4 nuts again.
- The minimum distance to the assembly plank is 5cm. Dowel the fixing plate to the wall or fix it using through bolts. Please observe the table on anchoring forces.

NOTE

Use extension tubes for longer distances between the hoist and the building (for example if a scaffold has been installed between the machine and the building. (see Fig. 3 and Fig. 4).



The mast anchoring tubes may only reach 2cm beyond the scaffold clamps! Risk of collision!

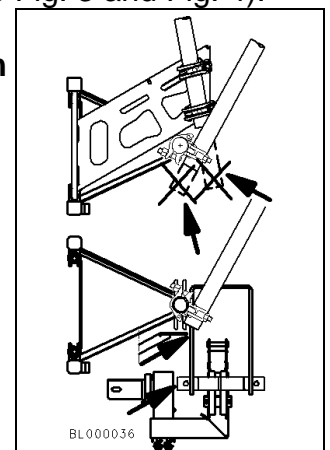

BL000036

- Use a stiff scaffold coupling to fix the telescopic tube to the circular tube of the mast (tightening torque **50Nm**). Extend the telescopic tube to the wall and also anchor it. The horizontal distance between the 2 anchoring tubes on the wall has to be as long as possible. (The minimum distance between the tubes is determined by the distance between the mast and the building. Use extension tubes for longer distances.)

NOTE

Vertical and rectangular alignment of the mast has to be checked and corrected if necessary.

- Vertical alignment of the mast is done by moving the anchoring tubes in the mast support or the scaffold clamp respectively.
- Rectangular alignment of the mast can be done using the two scaffold couplings (Fig. 37 Pos.5).

INSTRUCTIONS FOR THE TOP MAST BRACKET

If the mast is moved out over the top mast bracket during operation, a bracing tube (7) must also be mounted between the telescoping tubes (4+6).

- Mount bracing tube (7) as perpendicular as possible to the telescoping tube (4) in front of the mast bracket (1).

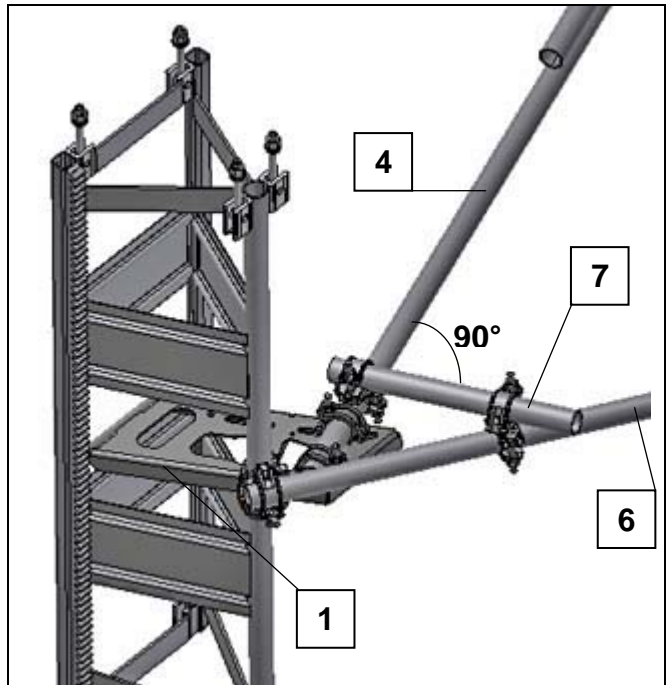

Fig. 39 Top mast anchoring for overrun and for assembly with landing level double doors



The mast may be moved out over the last mast bracket during operation to a max. of 1.75m (mast bracket to upper edge of sliding carriage).

7.3.3 Mast anchoring for assembly with a landing level double door

- Assembly of the mast bracket and telescoping tubes is exactly as described in section 7.3.2.

All mast anchors must be mounted as described in section 7.3.2

"Top mast anchoring" **with bracing tube** (Fig. 38 Pos. 7).

7.3.4 Putting on mast elements at heights between 4m and 10m

- Go up and install 3 further mast elements, see also Fig. 30/Fig. 31.



During mast assembly, you may only go up on the projecting mast end for a maximum of 5.5m beyond the highest mast anchoring (from the upper edge of the trolley to the mast anchor; maximum load = 250kg).

- Install further mast anchorings as it is described in chapter 7.3.1.

7.3.5 Assembling the mast elements above a height of 10m

The mast is now retained by at least two mast anchorings. This means that you can load the hoist car with at least **500 kg**.



Once a second mast anchoring has been installed (at a height of approx. 10m), the maximum load bearing capacity is 500kg.

- Install further mast elements as it has been described.
- Also install further mast anchorings as it has been described.
- For the installation of the mast anchorings, go up as far as necessary for these to be mounted easily. Please observe that the upper edge of the trolley may only move up on the projecting mast end for a maximum of 5.50m beyond the highest mast anchoring (with a load of 500 kg).
- Install further trailing cable guide at intervals of about 6m (see chapter 0).

Check the length of the trailing cable!

- Assemble the hoist up the desired height (maximum height = 100m).



Please observe the vertical distances for:
- mast anchorings max. 6,0m.
- trailing cable guides approx. 6,0m.

NOTE

The gear rack must be manually lubricated before first commissioning with new mast sections!

7.3.6 Emergency limit switch bar**Emergency limit switch bar**

- A limit switch bar (1) must be mounted as uppermost stop point before the drive pinions leave the gear rack. You have to keep a minimal distance of 1.25m to the upper end of the mast. (This bar will stop the hoist by activating the UP operational limit switch or the Emergency limit switch in case of a fault.)

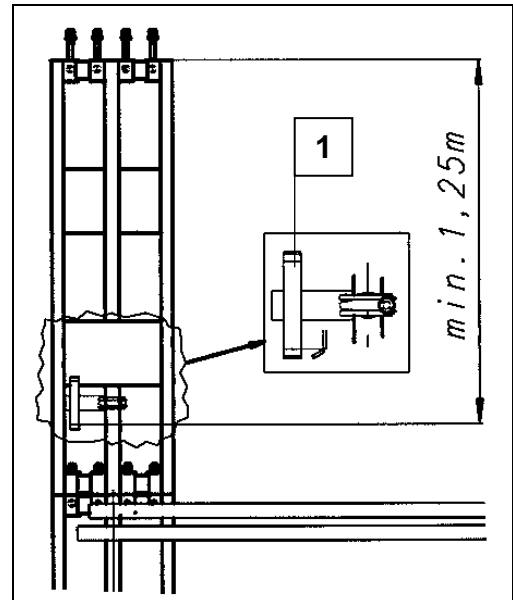

Fig. 40 Emergency limit switch bar



During operation, you may make the hoist move up on the mast for a maximum of 1.75m beyond the highest mast anchoring (mast anchoring to the upper edge of the trolley). You have to install the activating bar for the Emergency limit switch at according height.

7.4 Securing the loading and unloading points

You have to install anti-fall protections to all loading and unloading points at heights above 2m.

Only landing level gates which guarantee safe transfer to the building in combination with the hoist carrom are permitted for the tested and approved GEDA hoists.

GEDA landing level safety gates with serial numbers 01212, 01217, 29250 and 29280 have been tested and approved in combination with the GEDA- MULTILIFT P6. They fulfil these requirements.

NOTE Assembly of the landing level safety gates is described in additional assembly Instructions, which are supplied with the them.

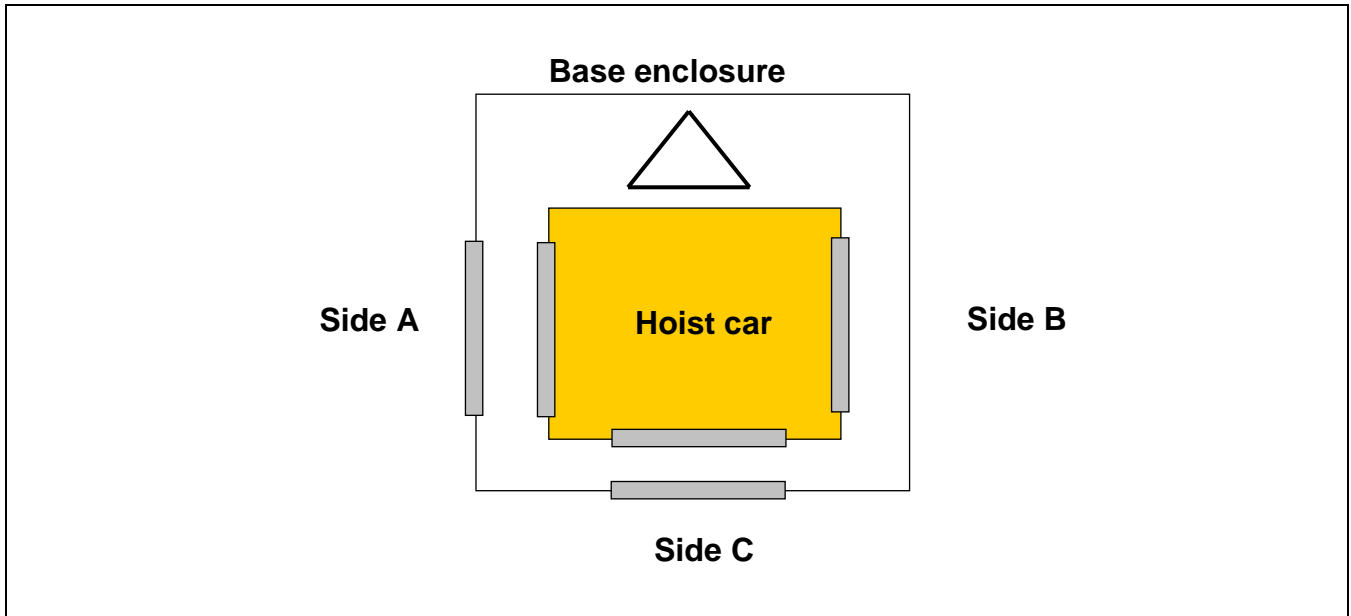

Fig. 41 Designation of the points of access

- The base enclosure (height = 1.10 m) for the **GEDA MULTILIFT P6 STANDARD** is designed with a barrier.
- You have to install an enclosure around the hoist at a minimal distance of 50cm.
- Mount the barrier in front of the access point on the ground.
(Look up chapter 4.5.1 for the installation of the enclosure and of the electric module of the base enclosure).
- The base enclosure (height = 2.50 m) for the **GEDA MULTILIFT P6 COMFORT** is designed with a sliding door.
-
- Side “A” is the access point at the base station.
- Side “B” is the transition to the landing level.
- Side “C” is another access point at the base station.
- If the sliding door of the hoist car on the landing level side does not have a ramp, a landing level safety gate with swing doors (Item No. 29250 or 29280) has to be installed as an anti-fall protection.
- If the sliding door of the hoist car on the landing level side has a ramp, a landing level safety gate with sliding door (Item No. 1212 or 1217) has to be installed as an anti-fall protection.

ATTENTION

The opening width of the landing level safety gate (Item No. 01212 and 01217) can be adjusted using a shiftable scaffold coupling.

Make sure that the loading ramp and the landing level safety gate are correctly, mutually and mechanically locked (please observe the operating manual for the landing level safety gate).

7.5 Landing level limit switch bar

- Placing the landing level limit switch bar into the mast element.
- Standing in the hoist car, hinge the landing level limit switch bar (1) to both mast connecting sheets (5) of the mast element. (The circular tube (2) of the landing level limit switch bar is lying in the recess of the upper mast connection.)
- Fix the limit switch activating bar (1) to both mast connecting sheets (5) using the clamping screws (3) as it is shown on the pictures on the right.



- Adjustment of the activating bar (4) has to be done depending on the type of landing level safety gate that is used.

Adjusting for the landing level safety gate swing door type

- Set the distance from the landing level floor to the opening of the variably adjustable activating bar (4) to 0.28 m.

Adjusting for the landing level safety gate sliding door type

- Set the distance from the landing level floor to the opening of the variably adjustable activating bar (4) to 0.265 m.

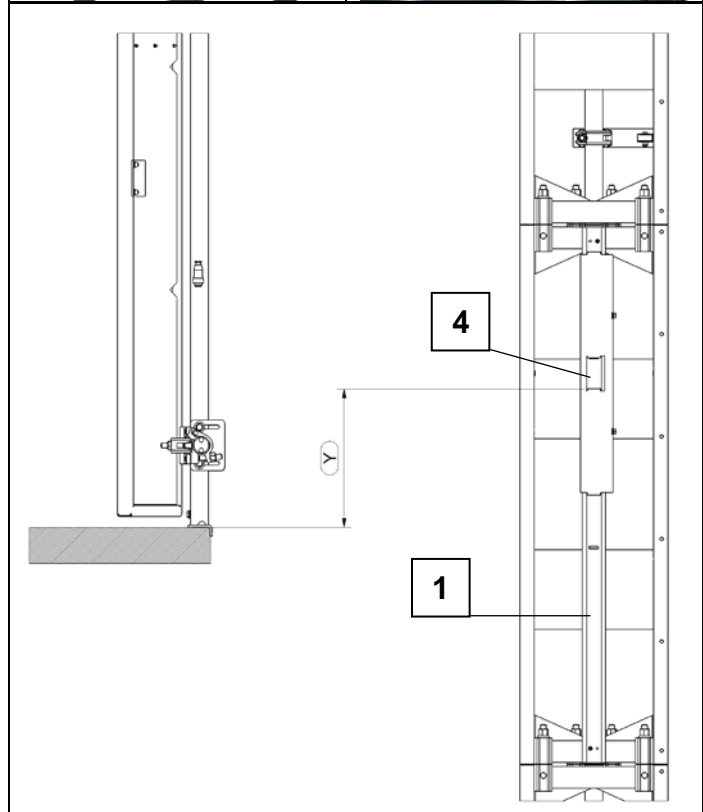

Fig. 42 Positioning the landing level limit switch bar

7.6 Inspection after assembly and before each beginning of operation

- Make sure that
 - the gear rack is sufficiently lubricated.
 - prescribed maintenance work and inspection procedures have been carried out.
 - there is no oil leakage at the gear motor.
 - the supply cable has a sufficient cross section.
 - the direction of motor rotation agrees with the UP/DOWN button
 - the trailing cable of the cable box is of sufficient length for the assembly height.
 - the danger zone (for the MULTILIFT P6 STANDARD) at the lower loading point is cordoned off.
 - plates/notices are present and legible (see Technical data).
- Carry out a test run with a **loaded** hoist car and check if the brake is functioning correctly.
- Check if the car control, ground control and level control are functioning correctly.
- The trailing cable, the mains supply line and the control lines must not show any damage.
- Test the functioning of the overspeed safety device by carrying out a drop test. (see chapter 11.9)
- Give the handover report and the documentation to the user.
- Hand over the key for the ground control to the authorized and instructed person.

8 Operation

8.1 Safety notes



The hoist may only be operated by a qualified person appointed by the contractor. This person must be familiar with the assembly and operating instructions, have sufficient experience, and has to be informed about the risks involved in working with the hoist.

- Cordon off the danger zone of the hoist (MULTILIFT P6 STANDARD).
- Nobody must stay beneath the hoist.
- No objects may be stored in the cordoned off area or below the hoist.
- Operating personnel (see chapter 3.4)
- The hoist must be operated from outside the danger zone.
- Secure the machine thoroughly against unauthorised access! – After work or during breaks, keep the manual control safe and/or turn off the main switch and secure with a padlock.
- If the loaded car stops during operation due to a malfunction, operating personnel must recover the load. - Never leave a loaded car unattended!
- Operation of the hoist must be stopped if:
 - wind speeds exceed 72 km/h (= wind force 7 - 8; stormy winds)
 - temperatures fall below -20°C
 - damage or other faults occur
 - any of the regular inspections has been missed (see chapter 2.3.1).
- Please be particularly careful near the ground.
- A maximum of 6 persons may travel on the platform. Thereby, you have to bear in mind that the transported material has to be reduced accordingly; the maximum load to be transported in the car is 650kg.

8.1.1 Rules for people travelling in the hoist car

- Follow the instructions of the hoist conductor.
- Do not step over material that is being transported.

8.1.2 Rules for ground personnel

- Nobody must stay underneath the hoist car.
- No objects may be stored in the cordoned off area or underneath the hoist car.
- Store materials at a minimum safety distance of 50 cm from moving parts of the hoist car.

8.1.3 Rules for loading and unloading the hoist car

- Anti-fall protections have to be installed at all loading points above a height of 2.0m to prevent people from falling down. (Install landing level safety gates.)
- The sliding doors at the landing level safety gates may only be opened after the loading ramp has completely folded out.
- You are only able to open the swing doors if the hoist car is directly positioned in front of the landing level.
- When loading the hoist car, make sure that all access points for loading and unloading remain unobstructed.
- Evenly distribute the load over the hoist car.
- Do not transport bulky parts that reach out of the hoist car.
- Make sure that the load is in a safe position. Secure all materials that could slip or fall.

ATTENTION

The brake release lever must never be used to lower the car during operation. It is intended for emergency use only (see chapter 10.1).

- Please observe also the safety instructions in chapter 2.

8.2 Safety inspections

Before starting work

Carry out a test run with an **empty** hoist car to find out if the entire travel path of the hoist car is unobstructed.

The hoist car must stop immediately if

- an EMERGENCY-OFF button has been pressed.
- a landing level safety gate has been opened.
- the DOWN limit switch has been reached.
- the upper limit switch activating bar has been reached or if the trolley has reached the end of the mast.

The hoist car must not be able to start if

- it is overloaded (the warning light of the control unit in the hoist car is illuminated).
- a sliding door or a barrier has been opened.
- the assembly guard has been lowered.
- the assembly plank is folded out.
- The overspeed safety device has triggered.

It must only be possible to open the sliding doors when the hoist car is on the ground or directly in front of a landing level.

If you use a control unit outside the hoist car (control units on the ground or at the landing levels), the hoist car of the **GEDA MULTILIFT P6 STANDARD** must not continue its journey automatically if

- The hoist car is near the ground (approx. 2 m).
- When the hoist car moves down it stops above the 2m safety height. You will hear a warning sound. You can only make the platform continue to move to the ground after this warning sound by pressing the DOWN button of the ground control or of one of the landing level controls. Going up by using the control units at the landing levels is only possible above the 2m safety height.

8.3 Operation

- Sliding doors must be closed. The assembly guard must be properly hung in above. Assembly planks must be closed and secured.
- Turn the main switch (on the switch cabinet of the cable box) to position ON.
- Turn on the key operated switch (5) of the ground control.
- Turn the key operated switch (6) of the hoist car control to operation.

8.3.1 Operating the GEDA MULTILIFT P6 STANDARD

1 = EMERGENCY-STOP button

Moving up

- Press the UP button (2).
- Within the first 2.0m from the ground you may only make the hoist car move by pressing the UP button (2) and keeping it pressed. Above the 2.0m safety height the UP button has to be released. The hoist car moves up automatically until it has reached the highest landing level and stops there.

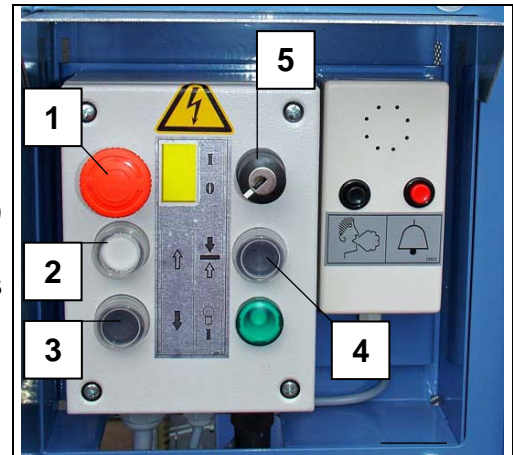

Ground control

- If you want the hoist car to stop at one of the landing levels in between, you have to press the landing level stop button (4) shortly before reaching that level.

Moving down

- Press the DOWN button (3) and release.
- The hoist car directly moves down until it has reached the 2.0m safety height.
- You can only make it move down the remaining 2.0m by using the control unit on the ground. Press the DOWN button (3) and keep it pressed (dead man's control mode).
- If you want the hoist car to stop at one of the landing levels in between, you have to press the landing level stop button (4) shortly before reaching that level.

7 = EMERGENCY-STOP button (does not engage)

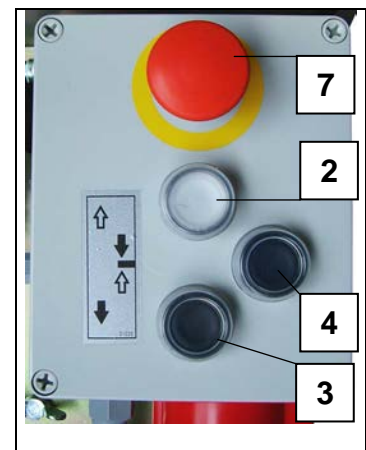

Control unit at the landing levels

1 = EMERGENCY-STOP button

Moving UP

- Press the UP button (5).
- Within the first 2.0m from the ground, the hoist car only moves up as long as the UP button (5) is kept pressed. Once the hoist car has passed the 2.0m safety height, you have to release the UP button (5). The hoist car automatically moves up to the highest landing level and stops there.
- If you want the hoist car to stop at one of the landing levels in between, you have to press the landing level stop button (7) shortly before reaching that level.

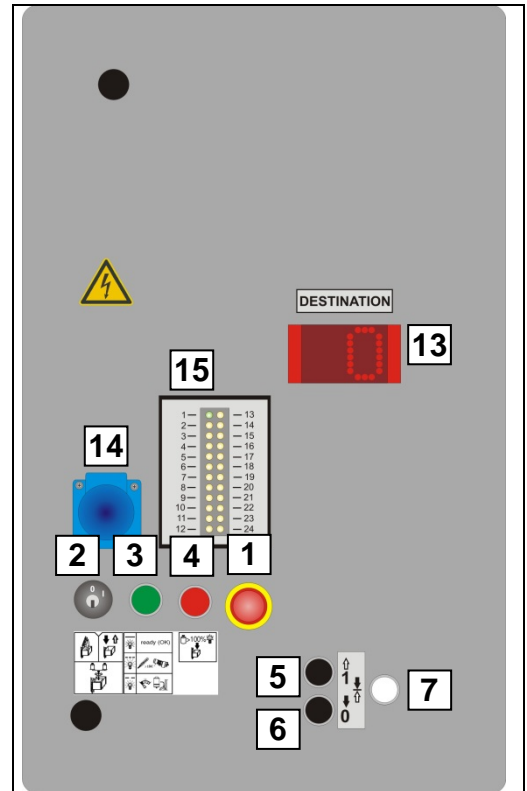

Moving down

- Press the DOWN button (6) and release it.
- The hoist car moves down and automatically stops approx. 2.0m above the ground. You will hear a warning sound for about 3 seconds. During this time control is interrupted.



The operator must only continue to make the hoist car go down having assured himself that the entire travel path below is unobstructed.

- Press the DOWN button (6) and keep it pressed. After the warning sound, the hoist car goes down until it has been automatically stopped on the ground by the limit switch.
- If you want the hoist car to stop at one of the landing levels in between, you have to press the landing level stop button (7) shortly before reaching that level.

8.3.1.1 Arriving at a landing level using external control units

- Swing up the barrier (1) of the base enclosure.



Fig. 43 Opening the barrier

- Open the sliding door of the hoist car.
 - Take the handle strip (2) and push up the sliding door as far as possible.
- Load or unload the hoist car.

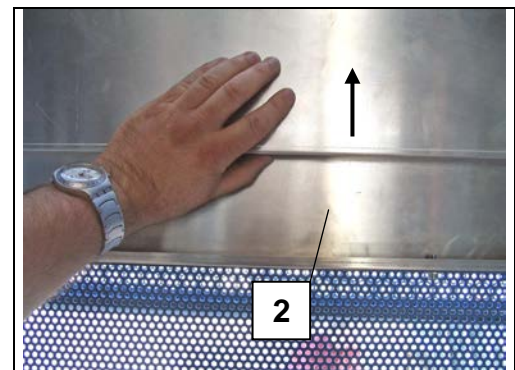

Fig. 44 Opening the sliding door

- Closing the sliding door of the hoist car.
 - Take the lower handle strip (3) and pull down the sliding door until it is completely shut.

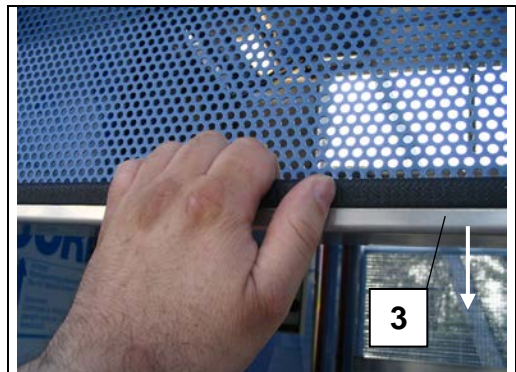

Fig. 45 Closing the sliding door

- Close the barrier of the base enclosure again.
- Press the UP button (ground control) and keep it pressed. Only release it having passed the 2.0m safety height.
 - The hoist car moves up to the highest landing level. If you want the hoist car to stop at one of the landing levels in between, you have to press the landing level stop button (4) shortly before reaching that level.

- At landing levels without a ramp, open the landing level swing doors
 - Take both handles and pull forcefully.
 - The swing doors will open.



Fig. 46 Opening the swing doors at the landing levels

- Open the hoist car's sliding door.

NOTE

For the sliding door with ramp, the ramp automatically folds out when the sliding door is opened.

- For sliding doors with a ramp, open the sliding door of the landing level.
 - Therefore push up the lever (into the direction of the arrow).
- Slide open the sliding door.

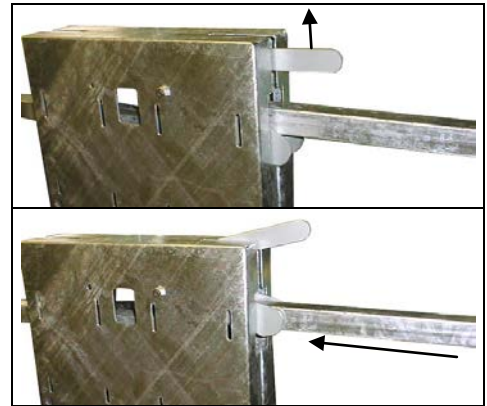

Fig. 47 Opening the sliding doors of the landing levels

- Load or unload the hoist car.
- If you want to make the hoist car move down, close the landing level safety gate again. The safety lever/ safety bar has to be engaged again.
- Shut the sliding door of the hoist car.
- Shortly press the DOWN button (of the ground control or the landing level control unit). The hoist car moves down until it has reached the 2.0m safety stop. (If you want the hoist car to stop at one of the landing levels in between, you have to press the landing level stop button (4) shortly before reaching that level.
- Press the DOWN button (of the ground control) again and keep it pressed.
 - After approx. 3 seconds (after the warning sound) the hoist car moves down until it will automatically be stopped by the limit switch.
- Swing up the barrier of the base enclosure.
- Open the sliding door of the hoist car.
- Load or unload the hoist car.

8.3.1.2 Going to a landing level using the control unit in the hoist car

- Swing up the barrier of the base enclosure.
- Open the sliding door of the hoist car.
- Now you can load the hoist with materials and tools. People can now enter the hoist car.
- Close the barrier of the base enclosure.
- Shut the sliding door of the hoist car.
- Press the UP button (2) and keep it pressed. After the hoist car has passed the 2.0m safety height, you have to release the UP button (2). The hoist automatically goes up to the highest landing level and stops there. If you want the hoist car to stop at one of the landing levels in between, press the landing level stop button (4) shortly before reaching that level.
- Open the sliding door of the hoist car.

NOTE

The ramp of the sliding door (if there is one) will fold out automatically when the sliding door is opened.

- Open the landing level safety gate.
- People in the hoist car can leave it now. Materials can be unloaded
- People may enter the hoist car for downward movement. Materials can also be loaded.
- Close the landing level safety gate again.
- Close the sliding door of the hoist car.
- Press the DOWN button (3) and release it. The car moves down and stops automatically approx. 2 m above the ground. You will hear a warning sound for about 3 seconds. During this period, control is interrupted. If the entire travel path below is unobstructed, press the DOWN button (3) again. After the warning sound, the hoist car moves down until it has been stopped by the limit switch.

If you want the hoist car to stop at one of the landing levels in between, you have to press the landing level stop button (4) shortly before reaching that landing level.



The operator may only continue to make the hoist car move after he has assured himself that the entire travel path below is unobstructed.

- Open the sliding door of the hoist car.
- Swing up the barrier of the base enclosure.
- People in the hoist car can now leave it. You can also unload the hoist car.

8.3.2 Operating GEDA MULTILIFT P6 COMFORT

1 = EMERGENCY-OFF button

Going UP

- Press the UP button (2) and release it.
- The hoist car directly moves to the highest landing level and stops there.
- If you want the hoist car to stop at one of the landing levels in between, you must press the landing level stop button (4) shortly before reaching this landing level.

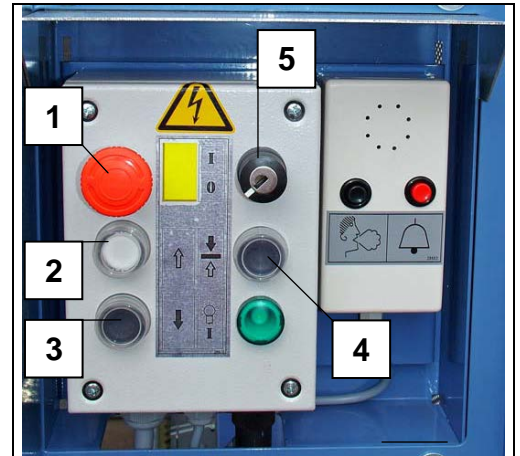

Ground control unit

Going DOWN

- Press the DOWN button (3) and release.
- The hoist car will go down to the ground station from whatever landing level.
- If you want the hoist car to stop at one of the landing levels in between, you have to press the landing level stop button (4) shortly before reaching this landing level.

7 = EMERGENCY-STOP button (does not engage)

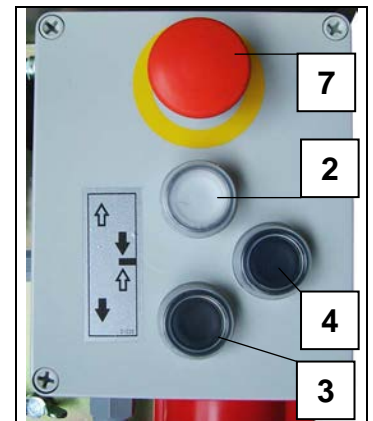

Control at the landing level safety gate

Going UP

- Press the UP button (5) and release it.
- The hoist car will automatically go up to the highest landing level and will stop there.
- If you want the hoist car to stop at one of the landing levels in between, you must press the landing level stop button (7) shortly before reaching this landing level.

Going DOWN

- Press the DOWN button (6) and release it.
- The hoist car moves down until it is stopped by the DOWN limit switch of the base unit.
- If you want to stop the hoist car at one of the landing levels in between, you must press the landing level stop button (7) shortly before reaching this landing level.

1 = EMERGENCY-OFF button

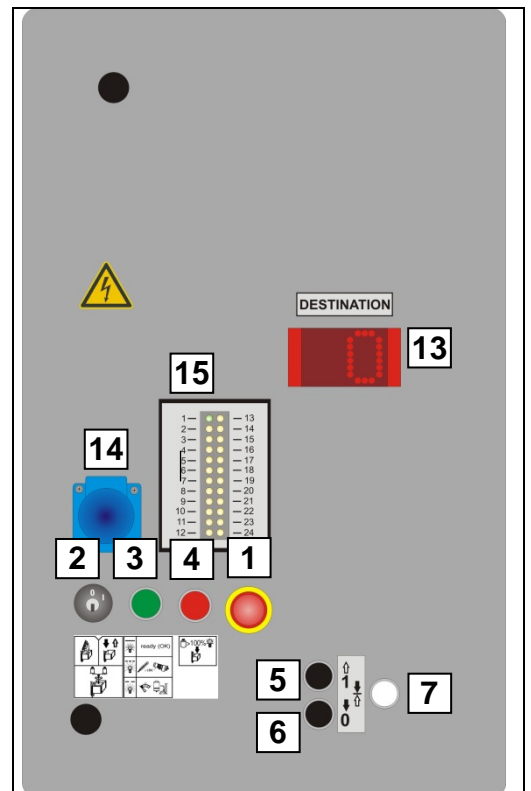

Control unit in the hoist car

How to use the control unit in the hoist car with landing level pre-selection [option]

1 = EMERGENCY-OFF button

Going to landing levels 1 to 9

- Choose the desired landing level by pressing the corresponding button for landing levels 1 to 9 (Pos. 2 or 8). Then press the start button (11). – The hoist car will go to the chosen landing level and will stop there.

Going to landing levels 10 to 19

- Choose the desired landing level by pressing the corresponding button for landing levels 10 to 19 (Pos. 9) and in addition the corresponding button for landing levels 1 to 9 (Pos. 2 or 8). Then press the start button – The hoist car will go to the chosen landing level and will stop there.

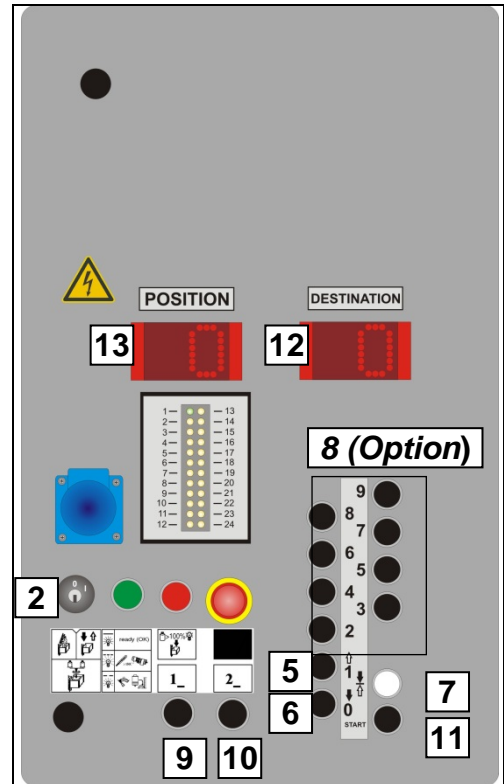

Landing level pre-selection control unit

Going to landing levels 20 to 29

- Choose the desired landing level by pressing the button for landing levels 20 to 29 (Pos. 10) and in addition the corresponding button for landing levels 1 to 9 (Pos. 2 or 8). Then press the start button (11). The hoist car will go to the chosen landing level and will stop there.

Going to the ground station

- Press the button for landing level 0 (Pos. 3). Then press the start button (11). – The hoist car will go to the ground station and will stop there.

8.3.2.1 Making the hoist car go to the landing levels using external control units

- Opening the sliding door of the base enclosure.
- Take the central handle strip (2) of the sliding door and push it up as far as possible.
- Open the sliding doors of the hoist car and of the base enclosure.
- Load or unload the hoist car.

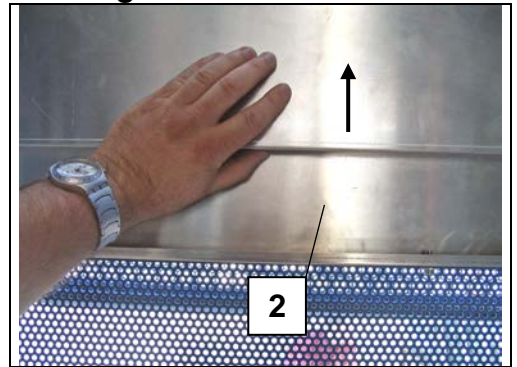

Opening the sliding door

- Closing the sliding door of the hoist car
- Take the lower handle strip (3) of the sliding door and pull it down as far as possible.
- Close the sliding doors of the base enclosure and of the hoist car.

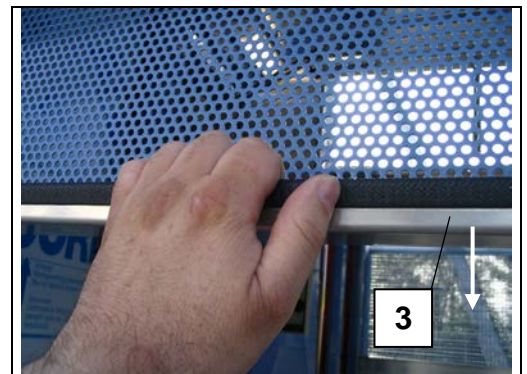

Closing the sliding door

- Press the UP button (ground control unit) and keep it pressed.
- The hoist car goes up to the highest landing level. If you want the hoist car to stop at one of the landing levels in between, you must press the landing level stop button shortly before reaching this landing level.
- For sliding doors without ramp, open the landing level swing doors
- Take both handles and open the swing doors by pulling forcefully.



Opening landing level swing doors

- Open the sliding door of the hoist car.

NOTE

For sliding doors with ramp, the ramp will fold out automatically when the sliding door is opened.

- Opening the landing level sliding door for sliding doors with ramp.
- Push the lever up (into the direction of the arrow).

- Slide the door open.

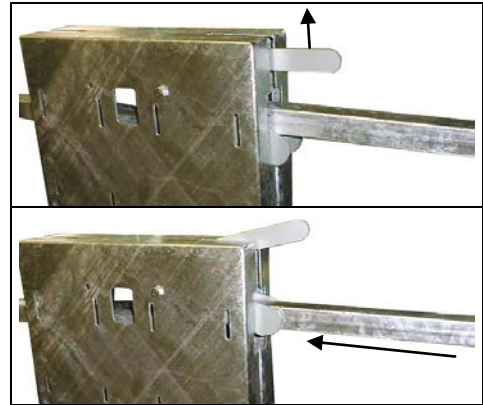

Opening the landing level sliding doors

- Now you can load or unload the hoist car.

- Making the hoist car go down if sliding doors without a ramp have been installed
 - Shut the sliding door of the hoist car.
 - Close the landing level swing doors.

- Making the hoist car go down if sliding doors with a ramp have been installed
 - Close the landing level sliding door. The safety lever/ bar must fully engage.
 - Shut the hoist car's sliding door.

- Shortly press the DOWN button (ground control unit or control units at the landing levels).
 - The hoist car will go down to the ground station and will stop there. If you want the hoist car to stop at one of the landing levels in between, you have to press the landing level stop button shortly before reaching this landing level.
- Open the sliding door of the base enclosure.
- Open the hoist car's sliding door.
- Now you can load or unload the hoist car.

8.3.2.2 **Going to the landing levels using the hoist car's control**

- Open the sliding door of the base enclosure.
- Open the sliding door of the hoist car.
- Now you can load the hoist car with materials and/ or tools. People may also enter the hoist car now.
- Close the sliding door of the base enclosure.
- Close the hoist car's sliding door.
- Press the UP button (2) and release it. The hoist car will automatically go up to the highest level and will stop there. If you want the hoist car to stop at one of the landing levels in between, you must press the landing level stop button shortly before reaching this landing level.

Model with landing level pre-selection control unit [option]

- *Choose the desired landing level by pressing the landing level selection button(s) (2, 8, and 10). Then press the start button (11). – The hoist car will move to the chosen landing level and will stop there.*
- Open the hoist car's sliding door.

NOTE

For sliding doors with ramp, the ramp will fold out automatically when the sliding door is opened.

- Open the landing level safety gate.
- People may now leave the hoist car. You can also unload materials.
- You can also load the hoist car or people may enter it for going down.
- Close the landing level safety gate.
- Shut the hoist car's sliding door.
- Press the DOWN button (3) and release it. The hoist car will automatically go down until the DOWN limit switch has stopped it on the ground.
If you want the hoist car to stop at one of the landing levels in between, you must press the landing level stop button shortly before reaching this landing level.

Model with landing level pre-selection control system [option]

- *Choose the ground station by pressing the button for landing level 0 (3). Then press the start button (11). The hoist car will go down to the ground station and will stop there.*
- Open the hoist car's sliding door.
- Open the sliding door of the base enclosure.
- Now, people can leave the hoist car. You can also unload materials.

8.4 Shutting down in case of an emergency

- In situations that are a potential risk for the operating personnel or the hoist, shut down the hoist car immediately by pressing an EMERGENCY STOP button.
- You can find an EMERGENCY-STOP button at the hoist car's control unit and at the control unit of the ground station.

NOTE

EMERGENCY-STOP push buttons are equipped with a catch mechanism. They remain active until they have been manually unlocked again (by turning the red button to the right and pulling it back).

8.5 Interruption work – at the end of work

- Make the car go down to the ground using the DOWN button.
- Turn down the key in the key operated switch of the hoist car's control unit and remove it.
- Turn the main switch to OFF and secure with a padlock.
- Remove the mains plug.

9 Dismantling the machine

The same rules and safety instructions as described in chapter 7 also apply for dismantling.

In general dismantling is carried out in reverse order to assembly. Please also note:

- Dismantle the landing level safety gates first (install the three-part protection first).
- Check if all mast connecting bolts are in contact.
- The hoist car must be stopped in a position that the mast joint of the mast to be removed is above the upper edge of the sliding carriage.
- Do not loosen the mast anchorings as long as there are still mast elements above them.
- Unload the hoist from time to time. (The hoist car cannot be made move if it is overloaded).

10 Fault – cause - remedy



Faults may only be remedied by qualified persons! If possible, make the hoist car move down and unload it before beginning with troubleshooting.

Turn off the main switch and pull out the mains plug before working on the hoist's electrical system. If faults occur that endanger operational safety, immediately stop working with the hoist.

If faults occur immediately check:

- Is the mains supply line plugged in?
- Is the main switch (on the cable box switch cabinet) turned on?
- Is the key switch on the ground control turned on?
- Are there fuses in the building site main cabinet (16A, slow-to-blow)?
- Is the correct extension cable being used (5 x 2.5 mm²)?
- Are the EMERGENCY STOP buttons at the control points unlocked?
- Are the sliding doors of the hoist car shut?
- Has the assembly guard been closed?
- Is the assembly plank closed?
- Has the Emergency limit switch been reached?
- Has the hoist car run too high/ too low (see chapters 10.1.3/ 10.1.4)?
- Is the proximity switch for gear rack surveillance at the right distance from metal (5-7 mm)?
- Are the activating elements for the up and down limit switches functioning properly?
- Has the overspeed safety device triggered (look up in chapter 10.2 how to release it)?
- Check the automatic circuit breaker in the switch cabinet for the cable box (primary fuse 3 A, control fuse 1 A).
- Is the key-operated switch on the car control unit set correctly for the mode of operation?
- Is the red control light (2) of the hoist car control unit illuminated (car overloaded)?
- Is the green control light of the ground control unit or the hoist car's control unit illuminated?
 - If not, read chapter 5.2 for electrical connection or the NOTE following this paragraph.
- Is the green control light (1) at the car control flashing?

➤ Continuous light → The hoist is ready for operation

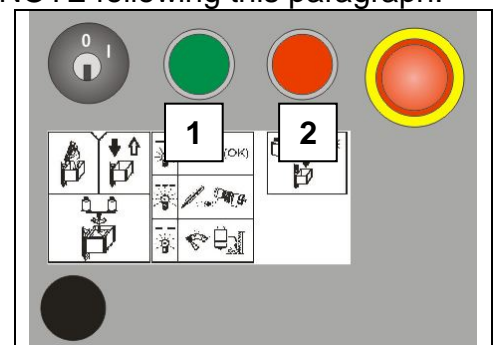

➤ Slowly flashing light → The lubrication device is lacking grease
The grease reservoir must be refilled before it empties.

➤ Fast flashing light → excess temperature of drive motors

NOTE

If the green control light is not illuminated, check the following points:

- Is there a phase failure?
- Is the phase sequence incorrect?
- If the phase sequence is incorrect, correct it on the phase inverter (mains supply line plug) by turning the two plug pins 180° using a screwdriver.
- Is the trailing cable plugged into the sliding carriage?
- Are the fuses in the cable reel switch cabinet correct and functioning?
-



Pull out the mains supply plug before opening the switch cabinet!

Motor is not producing full output:

- Voltage drop of more than 10 % of the rated voltage.
- Select supply cable with higher wire cross section.
- The integrated thermoswitch turns off the control current when overloaded. A fast flashing control light (2) on the car control warns against excess temperature on the drive motors. Work can continue after a certain cooling period (possibly reduce load).

ATTENTION Repeated overheating/overloading must be avoided. Otherwise the service life of the drive motor and motor brake are drastically reduced.

10.1 Diagnostic system (option)

The diagnostic system (1) provides quicker and easier identification of the switching status of the limit switch.

After input of the travel command, only the green diode must illuminate.

If this is not the case, the corresponding function or corresponding limit switch must be checked.

Switching status of the LED

green LED = standard ON

yellow LED = standard OFF

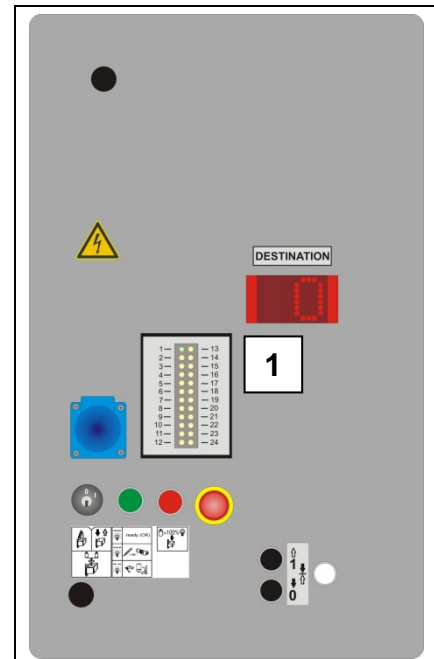

Significance of the LED / troubleshooting using the diagnostic system

- 1 = Ready for operation
- 2 = Illuminates if the EMERGENCY STOP line is interrupted. If only this LED illuminates, the EMERGENCY STOP line at the enclosure (access door, setting mechanism) or at one of the landing level safety doors is interrupted.
- 3 = Illuminates if the car door that faces the building is not locked.
- 4 = Illuminates if the car door that faces the enclosure is not locked.
- 5 = Illuminates if the EMERGENCY STOP in the car is activated.
- 6 = Illuminates if the EMERGENCY limit switch TOP or BOTTOM is activated.
- 7 = Illuminates if the limit switch of the safety gear is activated.
- 8 = Illuminates if the limit switch of the assembly guard is activated.
- 9 = Illuminates if the limit switch of assembly bridge 1 is activated.
- 10 = Illuminates if the limit switch of assembly bridge 2 is activated.
- 11 = Illuminates when the safety lock of assembly bridge 1 is opened.
- 12 = Illuminates if there is excessive tensile force at the travelling cable bracket.
- 13 = Not allocated
- 14 = Illuminates if the activation rail of the interlock cam is extended.
- 15 = Illuminates if the limit switch of the collision grille is activated.
- 16 = Not allocated
- 17 = Illuminates when the UP limit switch is activated.
- 18 = Illuminates when the DOWN limit switch is activated.
- 19 - 22 = no allocation
- 23 = Illuminates if the car has moved to the cable carriage.
- 24 = Not allocated

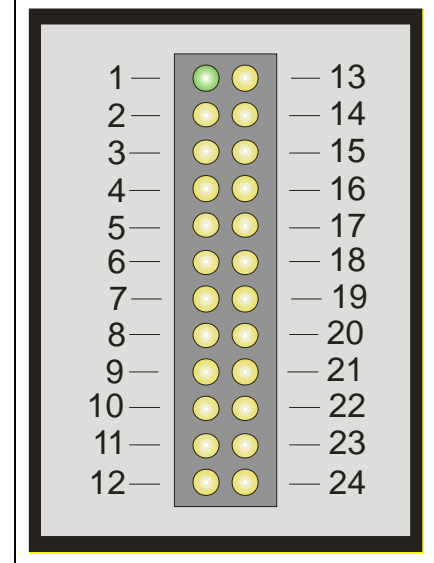

10.2 Faults that may occur during operation

10.2.1 Power failure or defective motor

In this case, the car must be lowered to the ground by releasing the motor brake.

- Take the brake release rod (1) out of its mount. (support profile of the assembly flap).
- Release the triangular wrench (2) and swing the cover plate (3) to the right side.
- Push brake release rod through the opening on the side panelling and guide to connecting rod of the brake release lever.

NOTE

You can check if the brake release rod has engaged by looking through the slots (4) of the interphone cover.

- Release motor brake by carefully metered pulling (towards the centre of the car) on the brake release rod (1). – The hoist car will glide down.
- Take out the brake release rod (1) again and put it back into its support profile.

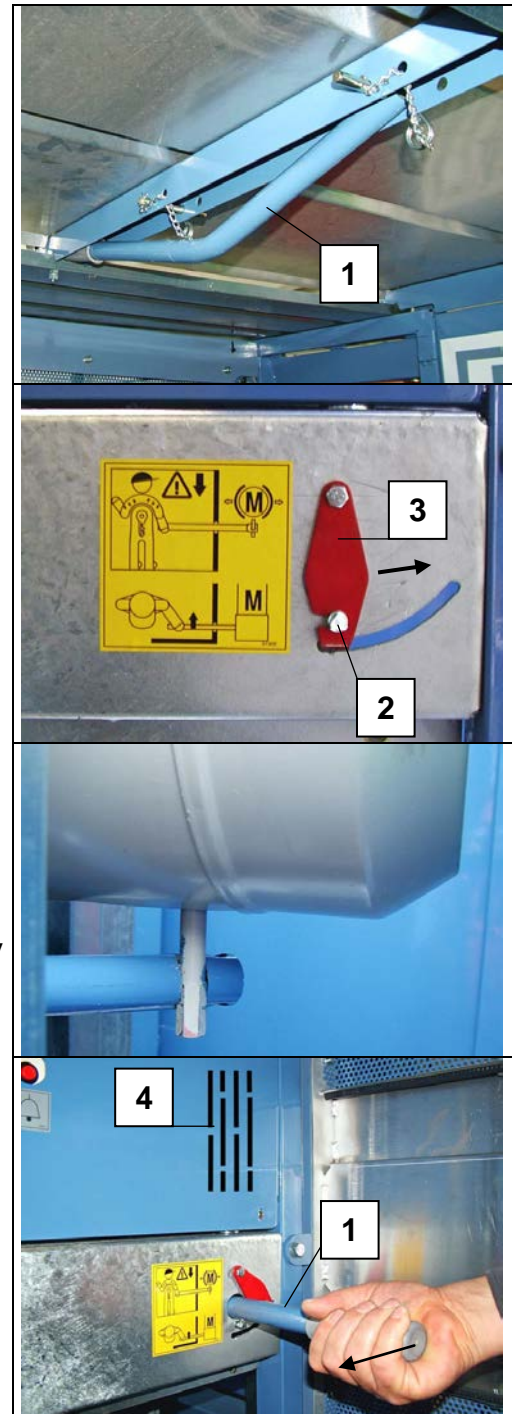

Fig. 48 Releasing the motor brake



You have to be very careful when using the brake release rod to prevent the overspeed safety device from triggering. Only lower the car very slowly! If the overspeed safety brake has engaged once, it will not be possible to go any further without raising the hoist car.

10.2.2 Recovering people locked inside the hoist car

It is not possible to lower the car by releasing the motor brake if e.g. the safety brake has triggered.

- Now check if parts of the drive system are broken, damaged or non-operational. In this case, the overspeed safety brake must not be stopped. **The hoist must be shut down!**
- Establish contact with the ground station via the interphone system and try to find a way how to go on.
- Leave the hoist car via the assembly plank.

NOTE

If the operator does not feel confident or qualified to organise and carry out the rescue, please notify the relevant authorities (fire brigade, technical support, factory security office).

- For emergency recovery, the assembly plank (together with the mast) can be unlocked from outside.
 - Turn down the safety interlock (1) anticlockwise.
 - Opening the assembly plank from the inside (see Fig. 35)
- The safety latch of the assembly plank can also be opened from the outside.
 - Press the base pan (3) inwards and press the lever (2) of the safety latch down.

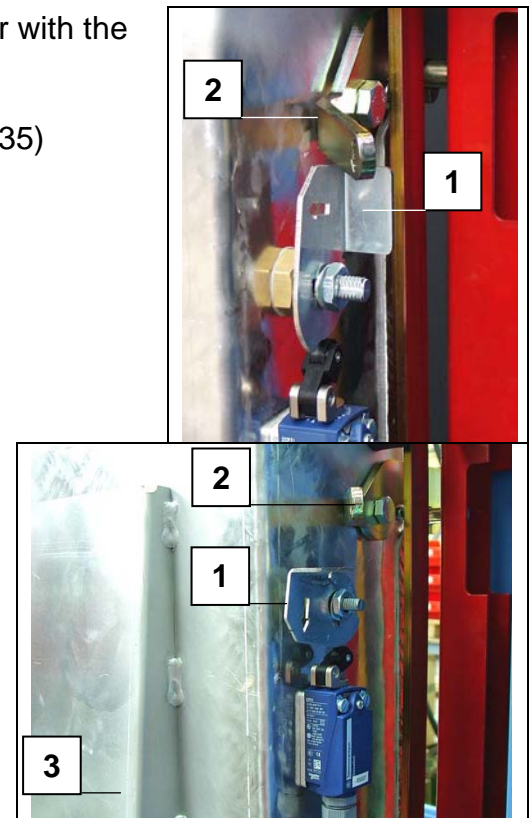

Fig. 49 Safety interlock

NOTE

If the safety interlock (1) is open, the control function is interrupted. After recovery/repair, the assembly plank must be closed and the safety interlock (1) must be swung up.

10.2.3 The hoist car has gone too high

The EMERGENCY limit switch of the hoist car may reach the upper EMERGENCY limit switch bracket if

- the UP limit switch is defective.
- there is a fault in the electrical system.

What to do:

- Activate the motor brake using the manual release lever (see chapter 10.1.1)

10.2.4 The hoist car has gone too low

The EMERGENCY limit switch of the hoist car may reach the lower EMERGENCY limit switch bracket if

- the air gap of the brake is too large.
- the DOWN limit switch is defective.
- there is a fault in the electrical system.
- the hoist car is overloaded.

What to do:

- Open the switch cabinet of the hoist car's control unit.
- Remove the dummy plug from the plug-in connection in the switch cabinet of the hoist car control.
- Plug in the drop test control at the plug-in connection (see Fig. 53).
- Press the UP button (3) outside the car.
 - The hoist car will leave the EMERGENCY –END position.



The UP button (3) must be pressed as this control by-passes the emergency limit switch. If the red catch control buttons are pressed by accident, the motor brake will be released and the motor may drop hard onto the foot section (risk of damage).

- If this effect occurs repeatedly although the car is not overloaded, have the brake checked and adjusted by a qualified person.

10.2.5 The hoist car is not able to recognise the selected landing level

If the car runs past the selected level or stops at the wrong level, a homing run down to the ground station must be carried out.

- Press the DOWN button (1) on the control units at the ground station, the landing level or in the hoist car and release. The hoist car moves down and stays at the (incorrect) level 0.
 - The remaining travel path to the ground station must be controlled manually.
- Press the DOWN button (1) of the control units on the ground, at the landing level or in the hoist car and keep it pressed.
 - After 30 seconds, the hoist car will slowly move down (approximate speed 12m/min.). It will be stopped by the lowest limit switch.
 - Now you can control the hoist car in the regular way again.

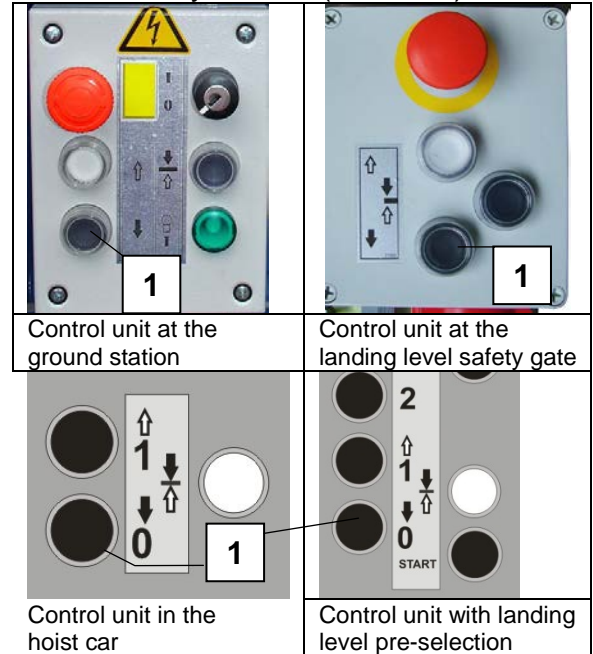

10.2.6 The overload warning device has triggered

The hoist is equipped with an overload warning device, which prevents the hoist car from starting to move if it is overloaded. If the hoist car is overloaded, a red control lamp at the hoist car control unit is illuminated.

If the control lamp is illuminated

- Reduce the load in the hoist car until the control lamp has gone off. – Only then may you make the hoist car move.

10.3 The overspeed safety device has triggered

The hoist is equipped with an overspeed safety device that brakes the hoist if it is moving too fast. It is not possible to make the hoist car move once the overspeed safety brake has triggered.



First, all persons have to leave the hoist car. Make out the cause for the overspeed safety device's triggering. Secure the hoist car and repair damages before releasing the overspeed safety device!

Releasing the overspeed safety device

- Open the switch cabinet of the hoist car's control unit.
- Remove the dummy plug from the plug-in connection in the switch cabinet of the hoist car's control unit.
- Plug in the drop test control unit at the plug-in connection (see Fig. 53).
- Press the UP button from outside the danger zone and make the hoist car go up for approx. 20 to 30 cm.

- Plug-out the drop test control after recovery and plug-in the dummy plug again.
- Close the switch cabinet of the hoist car's control.
- Remove the cover sheet (4) below the switch cabinet of the hoist car control unit.

(Allen key ● = 8mm)



- Loosen the safety nut (1) on the overspeed safety device.
- Turn the protective hood (2) of the overspeed safety device to the left until the limit switch lug (3) has engaged into the groove of the protective hood (2).
- Tighten the safety nut (1) again.
- The MULTILIFT P6 is ready for operation again.

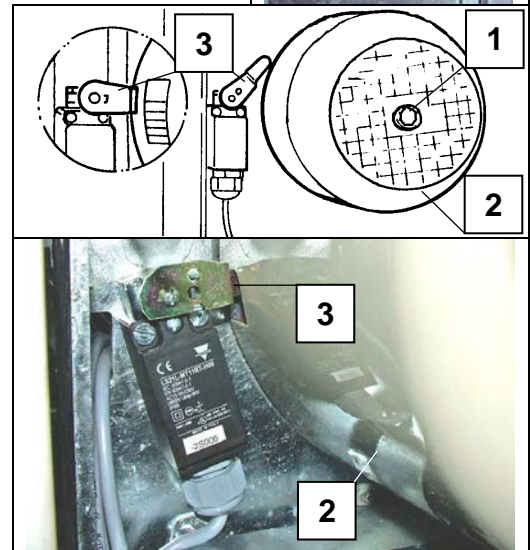

Fig. 50 Overspeed safety device

ATTENTION

Check the overspeed safety brake for damage, establish the cause of its triggering and rectify.

The overspeed safety device must be examined by a qualified person.

- Loosen the safety nut (1) on the overspeed safety brake, remove the protective hood (2) and check for any damage.
- Put on the protective hood (2) again. The limit switch lug (3) must engage into the groove of the protective hood.
- Tighten the safety nut again.
- Install the cover sheet below the switch cabinet of the hoist car control again.



The overspeed safety device prevents the hoist from going down by mechanically blocking it. You can only make the hoist car go down after making it go up a little bit first.

11 Maintenance



**Only qualified people may carry out maintenance work.
Dispose of lubricants and replacement parts in an environmentally friendly way.**

Report any changes or faults determined immediately to the company management or his/her authorised representative. If necessary, shutdown and secure the hoist immediately.

For MULTILIFT P6 COMFORT parts of the enclosure must be dismantled, the cable box must be rotated outwards or the hoist car must be made move above the enclosure for any servicing and maintenance work within the enclosure.

11.1 Setting mechanism

Before maintenance and service work are carried out within the enclosure on the ground, the setting mechanism has to be activated to protect maintenance personnel. The setting mechanism prevents the hoist car from going down below the 2m safety height.

- Make the hoist car go up above the setting mechanism.
- Turn off the main switch at the switch cabinet of the cable box and protect it with a padlock against being switched on.
- In order to activate the setting mechanism you have to swing away the cover (1) at the cable box.
- Push up the cover and swing away to the side.

NOTE

In order to reach the setting lever, you have to reach through the cable box.

- Swing up the setting lever (2): Lift it for unlocking. Push the setting mechanism to the side of the mast where the hoist car is.

NOTE

Once the hoist car is positioned above the base enclosure and secured, you can carry out maintenance and service work.

- After working within the base enclosure, pull out the setting mechanism (1) again and push the setting lever downward.

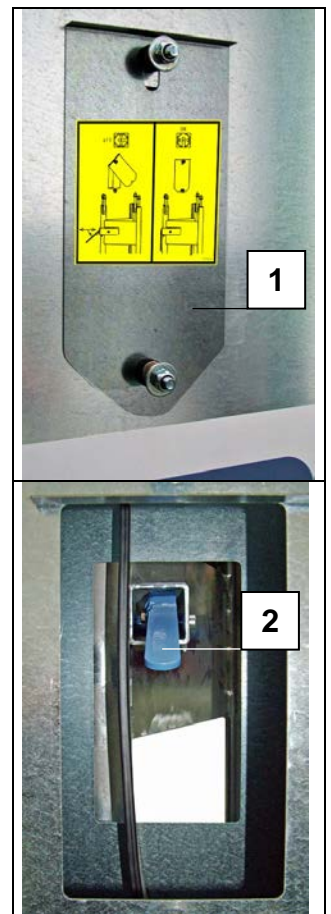

Fig. 51 Setting mechanism

NOTE

When the setting mechanism is activated, control is interrupted.
After maintenance work, the setting lever (2) must be returned to its vertical position.

- Remove the padlock from the main switch and switch it on again.
- Make the hoist car go down to the lower limit switch.

11.2 Daily cleaning

- Remove all the dirt from the hoist.
- Take away grease and chips/ shavings from the proximity switches (on the gear box case of the drive).
- Clear the cable box (keep free from snow and ice in winter).
- Keep working area around the hoist clear and clean.

11.3 Daily checks

- Visually check the entire travel path of the hoist car to make sure it is unobstructed.
- Carry out a test run with an empty hoist car and check if
 - the operating limit switch at the landing levels and at the ground station are functioning.
 - the sliding door latching devices are functioning; it should not be possible to make the hoist car move when a sliding door is open.
 - The EMERGENCY STOP button works if the hoist car cannot go up or down when the button is pressed.
 - The hoist car stops if a landing level safety gate is open.

Only for MULTILIFT P6 STANDARD

- Is the delay limit switch functioning? Automatic downward movement of the hoist must be stopped at the 2.0m safety height. Controlling the hoist car from the landing level control unit must not be possible within this zone at the bottom.
- Is the horn functioning? Coming down, the hoist car must stop at a height of approx. 2m above ground level. A warning sound will be heard for 3 seconds. (During this period control is blocked.)

NOTE

In case of faults read chapter 10.

11.4 Weekly inspection/ maintenance

- Check the brake path.
- Design with two different speeds
Make the loaded hoist car (observe load bearing capacity) stop when it is going down (for example 2m safety zone). The run-on of the motor brakes must not exceed 100 mm.
- Design with frequency converter
The frequency converter adjusts the motor speed downwards so that the brakes lock when almost at standstill.
- Check the gear rack and drive pinion for wear.
- For first lubrication or as an alternative to the automatic lubrication device, the gear rack can also be lubricated manually.
Recommended lubricant→ GEDA special spray Item No. 2524
Grease cartridge Item No. 16744 for grease gun

NOTE

The gear rack must be greased more often corresponding to increased use or multi-shift operation.

- Check the trailing cable, mains supply line and control lines for damage.

11.5 Monthly inspection/ maintenance

- Make sure that the mast connecting bolts, EMERGENCY limit switch brackets and mast anchorings/ bolts on the mast and on the building are firmly tightened and tighten if necessary.
- Rub the trailing cable with lubricant.
- Recommended lubricants: Continental Talcum powder
- Check the drive pinion and gear rack for wear; replace if necessary.

11.6 Quarterly inspection/ maintenance

- Are all signs in place and legible? (see chapter 4.3).
- Check lubrication device

The grease quantity in the container is enough for approx. 120 hours of normal operation. (The green control light on the car control flashes slowly if there is not enough grease.)

The grease reservoir must be refilled before it empties.

- Filling quantity: 1.2l

Recommended lubricant: Multi-purpose grease/cartridge for grease gun GEDA item no. 16744.

- Attach the manual lever grease gun to the filling nipple (1) (underneath the grease reservoir) and pump grease into the reservoir.
- Fill container to the "MAX" mark.



Fig. 52 Lubricating device

ATTENTION

Greases with solid lubricants are not suited to this pump.

Quick filling with filling gun

- Unscrew the dust cap from the filling connection (2) to fill up and insert the neck of the filling gun (3) to the stop point in the filling connection (2).
- Inject grease until the "MAX" mark is reached.

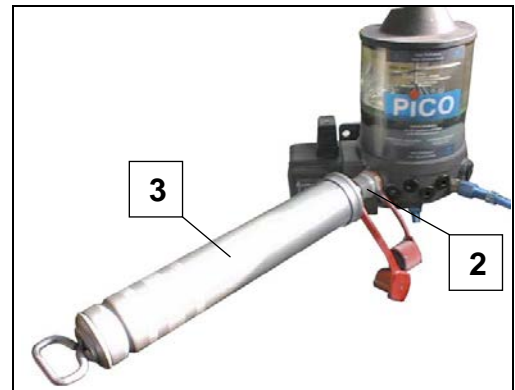
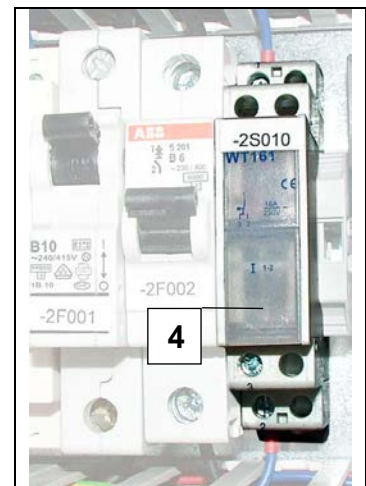

Fig. 53 Filling gun

- The functioning of the lubrication device can be tested using the "Test" button (4) in the switch cabinet of the hoist car's control.



Venting the system

If the grease level switch is defective and the pump has run completely dry, it may be necessary to vent the system.

- Fill up the pump via the filling nipple until the grease is approx. 4 cm above the "min. grease level" mark.
- Unscrew the lubrication hose from the pump housing.
- Remove the pump element or locking screw (M20 x 1.5) and keep open until bubble-free grease exits.
- Screw the pump element or locking screw back on.
- Keep triggering the lubricating impulse until bubble-free exits at the pump outlet.
- Reconnect the lubrication hoist, again.

11.7 Annual maintenance

- Check the gear oil and refill if necessary. Please observe also the external operating manual.

Recommended gear oil:

- Aral Degol BG 220
- ESSO Spartan EP 220
- BP Energol GR-XP 100
- Approximate quantity: 1.8 litres per drive unit
- Make sure that the toothed rack is firmly tightened
- Tightening torque: 70 Nm (8 mm Allen wrench).

11.8 Servicing the hoist every six years

The GEDA overspeed safety brake must be repaired or adjusted only by the manufacturer's service staff or its trained and authorised representatives.

The overspeed safety brake has been type-tested and must be replaced every 6 years or checked by the manufacturer or its authorised representatives.

11.9 Checking the overspeed safety device within the scope of regular inspections

(see chapter 2.3.1)

The drop test must only be carried out by a qualified person, who must have been appointed by the contractor. This person must be able to evaluate the risks and to assess the safe condition of the overspeed safety device, based on acquired knowledge, received training and practical experience.

NOTE

The catch control system has a direct effect on the contactors of the motor; it is also active when the PLC control for the car is switched off or has failed.

The sliding doors of the car cannot be opened when the catch control system is plugged in. After a drop test you have access to the hoist car using the assembly plank (see chapter 10.1.2) or via the sliding door of the hoist car, which has to be emergency released (see chapter 4.4.8).

- Turn the main switch to the ON position.
- Remove the dummy plug (5) from the plug-in connection in the switch cabinet of the hoist car's control unit.
- Plug-in the drop test control at the plug-connection (5) and take the manual control unit outside in front of the enclosure.

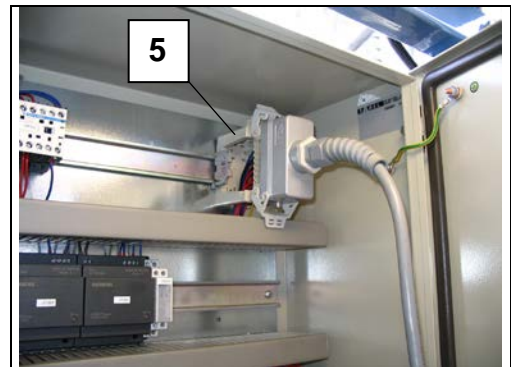

Fig. 54 Plugging in the drop test control unit

- Press the UP button (3) from outside the danger zone and make the empty hoist car go up to a height of approx. 5 m.
- Simultaneously press **both red buttons** (2). - The brakes of the drive units will open, the hoist car will glide down and reaches excessive speed. After 2 to 3m the overspeed safety device has to trigger and the hoist car must stop. If this is not the case, immediately release the buttons!
- Plug-in the dummy plug again after the drop test.

- 1 = EMERGENCY-OFF button
- 2 = "Brake release" button
- 3 = UP button
- 4 = DOWN button

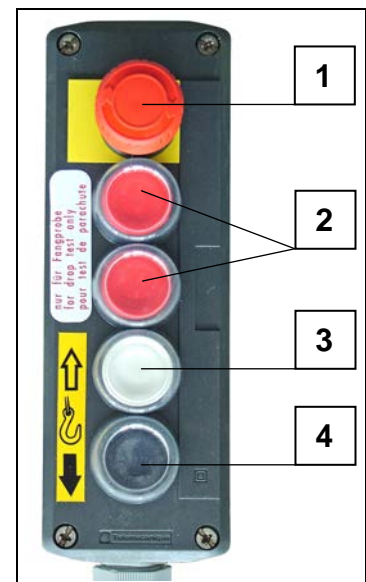

Fig. 55 Drop test control unit

ATTENTION

After the triggering of the overspeed safety device, the hoist car cannot be made move, because it is mechanically and electrically blocked. Read chapter 10.2 for releasing the overspeed safety device.

12 Repairs

Repair work may only be carried out by trained and qualified persons because this work requires special expert knowledge and special abilities. Both are not communicated in this operating manual.

When ordering spare parts, please indicate:

- Type
- Year of manufacture
- Serial number
- Operating voltage
- Desired quantity

The rating plate is located on the base unit of the machine.

NOTE

Spare parts must meet the manufacturer's technical requirements! Only use genuine spare parts from GEDA.

Order our customer service for servicing or maintenance work:

Manufacturer

GEDA Dechentreiter GmbH & Co. KG
 Mertinger Strasse 60
 D-86663 Asbach-Bäumenheim
 Tel.: +49 906 9809-0
 Fax: +49 906 9809-50
 E-Mail: info@geda.de
 Web: www.geda.de

Representatives of the manufacturer

Bergkamen Subsidiary	Gera Subsidiary
GEDA Dechentreiter GmbH & Co. KG Northwest branch Marie-Curie-Strasse 11 59192 Bergkamen-Rünthe Tel. +49(0)2389 9874-32 Fax. +49(0)2389 9874-33	GEDA Dechentreiter GmbH & Co. KG East branch Ernst-M.-Jahr Strasse 5 07552 Gera Tel. +49(0)365 55280-0 Fax. +49(0)365 55280-29
USA Subsidiary	Russia Subsidiary
GEDA USA, LLC 1151 Butler Road USA 77573 League City, Texas Tel. +1(713) 621 7272 Fax. +1(713) 621 7279 Web: www.gedausa.com	GEDA RUS, LLC Yaroslavskoe shosse 42 129337 Moscow Russian Federation Tel. +7(495) 663 24 48 Fax. +7(495) 663 24 49 Web: www.geda-ru.com
Turkey Subsidiary	
GEDA MAJOR IS VE INSAAT MAKINALARI SAN. TIC. LTD. STI. Semsettin Günaltay Cad. No:224 A Blok K:2 D:5 Tüccarbasi/Erenköy TR-34734 Istanbul/Turkey Tel.: +90 (216) 478 2108 Fax: +90 (216) 467 3564 Web: www.geda.com.tr	

13 Disposing of the machine

Dismantle the equipment properly at the end of its service life and dispose of according to national regulations and prescriptions.

- Observe the following when disposing of equipment components:
 - Drain and dispose of oil/grease in an environmentally friendly way
 - Recycle metal parts
 - Recycle plastic parts
 - Take electrical components to hazardous waste recycling.

Recommendation: Contact the manufacturer or commission a specialist company to handle disposal requirements in accordance with regulations.

14 Warranty

Please find the warranty conditions in the general business conditions (see invoice or delivery note). Not included in the warranty are damage or defects that occur as a result of non-prescribed electrical connection, improper handling, non-compliance with the assembly and operating instructions. Electrical cables and parts that are subject to normal wear and tear are also excluded. We reserve the right to determine how and through whom the defects are to be remedied.

15 Appendix for the results of regular inspections

Results of the inspection

Date and signature of the inspector

Results of the inspection

Date and signature of the inspector

Results of the inspection

Date and signature of the inspector

Results of the inspection

Date and signature of the inspector

Results of the inspection

Date and signature of the inspector

Results of the inspection

Date and signature of the inspector

Results of the inspection

Date and signature of the inspector

Results of the inspection

Date and signature of the inspector

Results of the inspection

Date and signature of the inspector

Results of the inspection

Date and signature of the inspector

Results of the inspection

Date and signature of the inspector

Results of the inspection

Date and signature of the inspector